

## FACT SHEET

# RADIAL ARM SAWS

A radial arm saw is a circular saw mounted on a sliding horizontal arm. It is often used for cutting long pieces of timber to length. It may be fitted with a dado blade to create cuts for dado, rabbet (a recess or groove cut into the edge of a piece of material) or half lap joints. A dado blade is usually one of a pair, mounted on the spindle and separated by spacers to set the width of a groove in timber.

When a radial arm saw is used for cross cutting, the timber remains stationary on the saw's table, and the blade is pulled through the timber. Some radial arm saws allow the blade to turn parallel to the back fence, using a rip cut.

FIGURE 1: RADIAL ARM

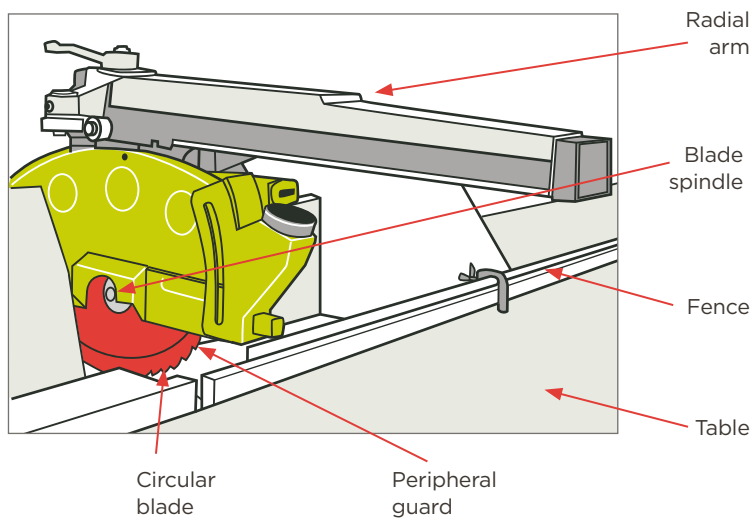

### HAZARDS:

- > Contact with blade
- > Noise
- > Dust
- > Slips, trips and falls
- > Unexpected movement (during maintenance, cleaning & adjustments)

### PPE:



## TASK - FEED AND GUIDE TIMBER THROUGH THE CUT

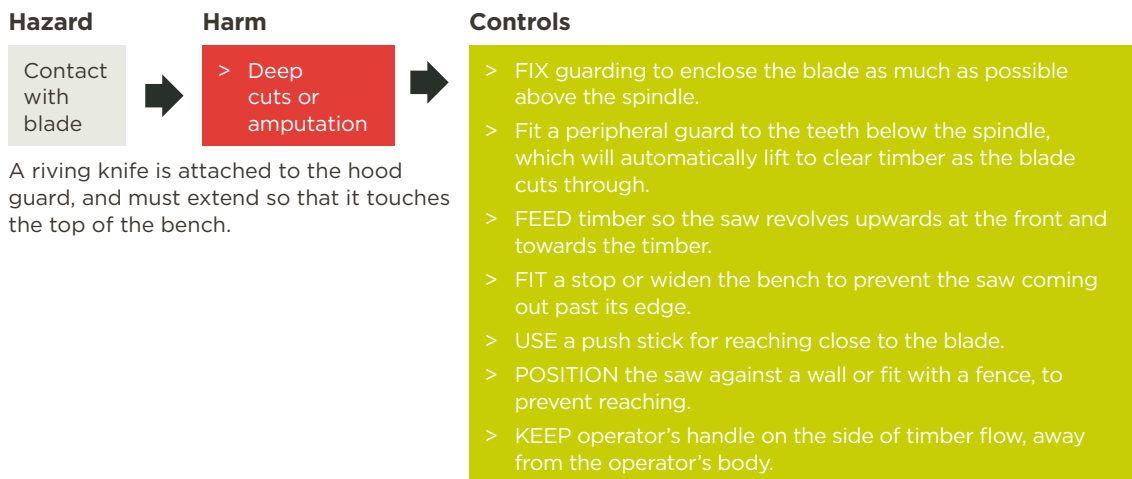

## OTHER (NON-MECHANICAL) HAZARDS

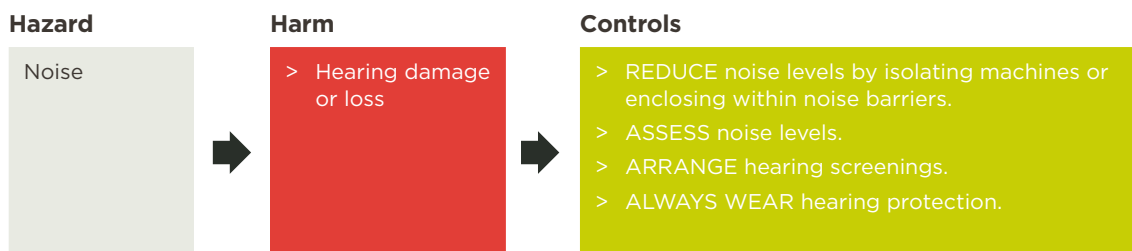

A safe noise level over an eight hour day is 85dB(A). A radial arm saw may exceed the noise intensity.

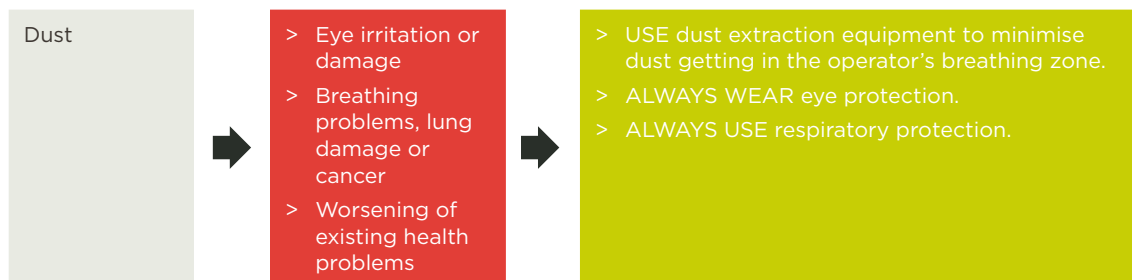

---

## TASK - MAINTENANCE, CLEANING & REPAIRS

Hazard	Harm	Controls
Contact, impact or entanglement from unexpected movement	<ul style="list-style-type: none"><li>&gt; Trapping injuries</li><li>&gt; Cuts</li><li>&gt; Bruising</li></ul>	<ul style="list-style-type: none"><li>&gt; LOCK-OUT power and wait for blade to stop turning before maintenance, cleaning or repairs.</li><li>&gt; KEEP written safety procedures.</li><li>&gt; ARRANGE regular inspections by a competent person.</li><li>&gt; REMOVE or LOCK-OUT machines that fail inspection, and DO NOT USE until repaired or replaced.</li><li>&gt; Carry out a new HAZARD ASSESSMENT following any alterations, and make necessary safety improvements.</li></ul>

### RIPPING WITH A RADIAL ARM SAW

Radial arm saws can be used above the bench for ripping.

Timber MUST be fed so the saw revolves upwards at the front and towards the timber (see Figure 2). If the timber is fed from the other side with the saw revolving down and in the direction of the feed, the teeth will likely “dig-in” or “climb”.

**FIGURE 2: CORRECT**

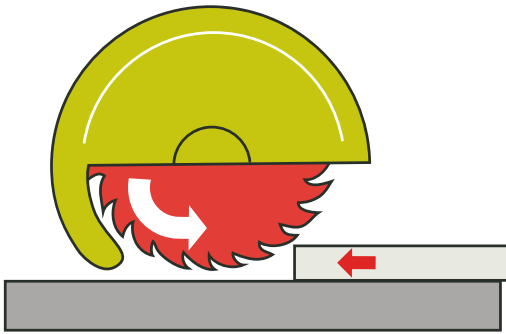

**FIGURE 3: INCORRECT**

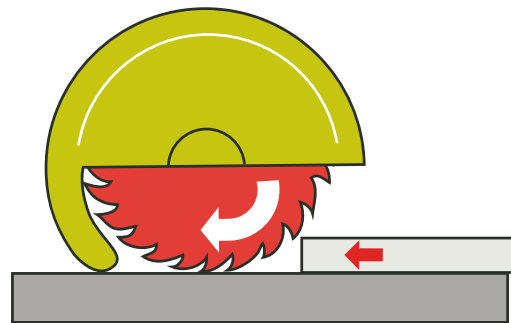

References, current standards and further information can be found on the Safe Use of Machinery project page at: [www.worksafe.govt.nz](http://www.worksafe.govt.nz)

---

PUBLISHED: APRIL 2014. CURRENT UNTIL REVIEW IN 2017