



Approved Code of Practice for Load-lifting Rigging

DECEMBER 2012



DDL 12030 DEC 12



**Ministry of Business,
Innovation & Employment**

ACKNOWLEDGEMENTS

The Ministry of Business, Innovation and Employment thanks the Lifting Equipment Engineers New Zealand Incorporated for their support and assistance with the Code's revision. The Ministry also appreciates the input from the people and organisations that provided submissions on the proposed changes.

Cover page photograph: A crane lifting a concrete wall into place at a construction site. Photo by Yellow Garnet Photography/iStockphoto.

Disclaimer: The Ministry of Business, Innovation and Employment has made every effort to ensure that the information contained in this report is reliable, but makes no guarantee of its accuracy or completeness and does not accept any liability for any errors. The information and opinions contained in this report are not intended to be used as a basis for commercial decisions and the Ministry accepts no liability for any decisions made in reliance on them. The Ministry may change, add to, delete from, or otherwise amend the contents of this report at any time without notice.

The material contained in this report is subject to Crown copyright protection unless otherwise indicated. The Crown copyright protected material may be reproduced free of charge in any format or media without requiring specific permission. This is subject to the material being reproduced accurately and not being used in a derogatory manner or in a misleading context. Where the material is being published or issued to others, the source and copyright status should be acknowledged. The permission to reproduce Crown copyright protected material does not extend to any material in this report that is identified as being the copyright of a third party. Authorisation to reproduce such material should be obtained from the copyright holders.

First edition published 1974
Revised 1979
Revised 1983
Reprinted 1989
Reprinted 1990
Revised 2001 ISBN 0-477-03595-7

ISBN: 978-0-478-40122-6 (print)
978-0-478-40123-3 (web)

November 2012
© **Crown copyright 2012**

Ministry of Business, Innovation and Employment
PO Box 3705
Wellington
New Zealand
www.mbie.govt.nz

NOTICE OF APPROVAL

The construction industry plays an important role in New Zealand, working hard to educate its members to a high standard of health and safety. However, it is an industry with significant risks that must be well managed. Load-lifting rigging is a critical aspect of transporting materials over distance and height, and if not done so safely, serious accidents and damage to property can occur.

This Approved Code of Practice has been developed by the Ministry of Business, Innovation and Employment in partnership with industry representatives and other agencies. It is focused on improving safety practices and reducing workplace accidents in the industry.

In May 2012, the Government announced a target of reducing workplace deaths and serious injuries by at least 25 percent by 2020. This code, as a joint initiative of the Ministry and the industry, will play a role in achieving that goal.

I approve this code of practice under section 20 of the Health and Safety in Employment Act 1992. It is a statement of preferred work practices. A Court may consider it when considering compliance with relevant sections of the Act. If an employer can show compliance with all the matters it covers, a Court may consider the employer has complied with the Act.



Hon Christopher Finlayson
Acting Minister of Labour

The approval date of this Approved Code of Practice is 21 November 2012. The commencement date of this Approved Code of Practice is **21 May 2013** to allow for a transition period from the approval date.

FOREWORD

As Deputy Chief Executive of Safety and Regulatory Practice at the Ministry of Business, Innovation and Employment, it gives me great pleasure to introduce this Approved Code of Practice for Load-Lifting Rigging (5th edition).

The Ministry is resolute in its commitment work in partnership with industries to reduce the number of workplace fatalities, injuries and occupational disease. In 2011, with two million people working in about 470,000 workplaces, 85 people were killed– that’s 85 colleagues, friends, and family members. Another 445 people were seriously injured, some requiring months of medical treatment and rehabilitation. 33,800 ACC claims were filed for work-related injuries¹.

This toll is too high. We must all work together to ensure that all working New Zealanders return home at the end of their working day to their families, their friends, and their communities. We encourage you to work with us to help achieve our goal of reducing worker injuries by at least 25 percent by 2020.

The Lifting Equipment Engineers New Zealand (Inc) has worked hard with the Ministry to revise and update the Code’s previous edition. Along with the valued input from a range of stakeholders with interest in load-lifting rigging in construction, what has been produced is an Approved Code of Practice of high quality that will lead to higher sustainable levels of health and safety in the industry.



Lesley Haines
Deputy Chief Executive, Safety and Regulatory Practice, Ministry of Business,
Innovation and Employment
November 2012

¹ [The State of Workplace Health and Safety in New Zealand](#) (June 2011). Department of Labour, Wellington.

TABLE OF CONTENTS

PART 1: INTRODUCTION	9
1.1 Scope and application.....	9
1.2 Legislation	9
1.3 Interpretation.....	9
1.4 Definitions	10
PART 2: GENERAL SAFETY AND EQUIPMENT	17
2.1 General	17
2.2 Safety systems.....	17
2.3 Personal safety	17
2.4 Tools and equipment.....	18
2.5 Further information	18
PART 3: EQUIPMENT AND APPROPRIATE SAFETY FACTORS	19
3.1 Identification	19
3.2 Factors of safety	19
3.3 Flat web and round slings	19
3.4 Manilla rope	23
3.5 Chain and chain slings	25
3.6 Uniform method: grade 8	26
3.7 Trigonometric method: grade 80	27
3.8 Wire rope.....	28
3.9 Components.....	28
PART 4: ROPE SPLICES.....	31
4.1 Fibre rope	31
4.2 Wire rope.....	31
4.3 Wire rope thimbles.....	31
4.4 Wire rope (bulldog) grips	32
PART 5: FITTINGS, SHEAVES AND BLOCKS.....	36
5.1 Wedge-type rope sockets.....	36
5.2 Rings	36
5.3 Shackles.....	37
5.4 Rigging screws and turnbuckles	40
5.5 Snatch, sheave and cargo blocks	42
5.6 Lifting beams, spreaders and frames	43
5.7 Eyebolts for lifting.....	44
5.8 Chainblocks.....	45
5.9 Lever block	46
5.10 Hooks.....	46
5.11 Other general gear.....	46
5.12 Inspection	46
5.13 Register	47
PART 6: RIGGING FOR CRANE WORK	49
6.1 General safety requirements	49
6.2 Evaluating the load	49

6.3	Load estimation – weight and centre of gravity.....	50
6.4	Figure 22: Volumes of common shapes.....	52
6.5	Load security – balance and stability	53
6.6	Structures.....	54
6.7	Packing	55
6.8	Slings.....	56
6.9	Good slinging practice	67
6.10	Radio communication	73
6.11	Winches, sheaves and purchases for flexible steel wire rope	74
6.12	Rigging blocks	88
6.13	Handling steel plate.....	92
APPENDIX 1: THE HEALTH AND SAFETY IN EMPLOYMENT ACT 1992		95
	Object of the Act	95
	Regulations	95
	Approved Codes of Practice	96
	Employers’ duties.....	96
	Hazard management	96
	Information for employees and health and safety representatives	97
	Training and supervision of employees.....	98
	Responsibility for employees’ work activities	98
	Persons in control of a place of work.....	98
	Duties of the self-employed	98
	Duties of principals.....	98
	Hirers, sellers and suppliers of plant	99
	Duties of employees	99
	Accidents and serious harm recording and notification	100
APPENDIX 2: THE HEALTH AND SAFETY IN EMPLOYMENT REGULATIONS 1995		102
	General duties of employers	102
	Managing specific hazards	102
APPENDIX 3: THE HEALTH AND SAFETY IN EMPLOYMENT (PRESSURE EQUIPMENT, CRANES AND PASSENGER ROPEWAYS) REGULATIONS 1999		104
	Notification duties	104
APPENDIX 4: CRANE HAND SIGNALS		105
APPENDIX 5: REFERENCE DOCUMENTS		107
	New Zealand and Australian standards.....	107
	European and other international standards.....	107
	Related publications list.....	109

LIST OF FIGURES

Figure 1: Flat eye sling	21
Figure 2: Reversed eye sling	21
Figure 3: Plain dee sling	21
Figure 4: Dee sling with choker	21
Figure 5: Endless sling	21
Figure 6: Wide load loop sling	21
Figure 7: Reduced eye sling	21
Figure 8: Wire rope (bulldog) grip	32
Figure 9: Wire rope (bulldog) grip	32
Figure 10: Correct method of using bulldog grips to form an eye	33
Figure 11: Incorrect method of using bulldog grips	33
Figure 12: The measurements featured in these diagrams relate to table 11.	34
Figure 13: Wedge-type rope sockets	36
Figure 14: Large dee shackle	39
Figure 15: Types of rigging screw	40
Figure 16: Types of turnbuckle	41
Figure 17: Examples of sheaves and cargo blocks	42
Figure 18: Calculation for single sheave block (note: SWL should read as WWL)	43
Figure 19: Examples of lifting beams.....	44
Figure 20: Examples of the centre of gravity of loads	51
Figure 21: Example of a load being lifted where the hook is not over the centre of gravity	52
Figure 22: Volumes of common shapes	52
Figure 23: Minimum recommended corner radius for lifting	55
Figure 24: Good standard with adequate radius and no kinking	56
Figure 25: Calculations for two-leg slings.....	57
Figure 26: Single-leg slings.....	58
Figure 27: Single-leg slings in basket hitch	59
Figure 28: Two single-leg slings used together	61
Figure 29: Two-leg slings.....	62
Figure 30: Basket hitch and four-leg sling examples	63
Figure 31: Shortening clutch	68
Figure 32: Hammering down is dangerous	69
Figure 33: Compression impacting on a roof truss	70
Figure 34: Using tag lines	71
Figure 35: Storing chain slings	72
Figure 36: sheave groove with rounded-off flared edges.....	74
Figure 37: Reducing the number of parts.....	76
Figure 38: Checking groove for wear.....	77
Figure 39: Jockey sheave	78
Figure 40: Examples of lay rope	79
Figure 41: Grooved drum calculation example	80
Figure 42: Effect of fleet angle on spooling	81
Figure 43: Number of running sheaves in each pulley block	82
Figure 44: Determining the capacity of a reel for rope storage	84
Figure 45: Cable pulling stockings.....	85
Figure 46: Cutting a rotation-resistant rope	86
Figure 47: Calculating tension for sling legs	86

Figure 48: Multiplication factors for snatch block loads	89
Figure 49: Tension on two falls drifting a load	91
Figure 50: Drifting a load.....	92
Figure 51: Examples of plate clamps.....	93
Figure 52: Correct method of turning over a load	94
Figure 53: Correct method of turning over a steel bin	94

LIST OF TABLES

Table 1: Web slings - WLL capacity (WLL 6:1 capacity rating in tonnes).....	20
Table 2: Six types of slings	21
Table 3: Colour coding and lifting capacity of synthetic slings (tonnes)	22
Table 4: Maximum WLLs for slings in three-strand hawser laid constructions	23
Table 5: Maximum WLLs for slings made of Grade 1 Manila ropes	24
Table 6: WLLs: General purpose Grade 80 chain slings - uniform load method	26
Table 7: Special-purpose slings - trigonometric method of rating	27
Table 8: WLLs for slings constructed from wire ropes with fibre cores 6 x 19 to 6 x 41	29
Table 9: WLLs for slings constructed from wire rope with steel cores 6 x 19 to 6 x 41.....	29
Table 10: Wire rope grips to DIN 1142	33
Table 11: Wire rope grips - federal specification FCC-450	34
Table 12: Required tightening torque and minimum number of FCC-450 grips to attain 80% of rope minimum breaking load.....	35
Table 13: US Federal Specification RR-C-271.....	38
Table 14: Large dee shackles to US Federal Specification RR-C-271	39
Table 15: WLLs for rigging screws and turnbuckles to BS4429	42
Table 16: Maximum recommended working loads for collar eyebolts when used in pairs for inclined loading positions	45
Table 17: Example register	48
Table 18: Example of material weights	50
Table 19: Relationship between uniform load method and WLL of single- and multi-leg slings	67
Table 20: Temperatures and WLL reduction	70
Table 21: Recommended minimum sheave diameters for maximum rope life - multiple of rope diameter	75
Table 22: Tabulated safe loads	82
Table 23: Tabulated method.....	85
Table 24: Multiplication factors for snatch block loads.....	90

PART 1: INTRODUCTION

This Approved Code of Practice (the "Code") provides recommendations and procedures for safe practice while carrying out lifting and rigging work in industry. In an industry with inherent dangers involving lifting, this Code will assist to increase the focus on safety.

1.1 Scope and application

This Code applies to all places of work at which persons such as an employer, employee, self-employed person, contractor or subcontractor has to use lifting and rigging practices in the course of their duties.

1.1.1 Exclusions

This Code also applies to dry dock and wharf usage, but not ships' gear.

- (a) *Maritime Rules Part 49 (Ships' Lifting Appliances)* deals with the testing, examination and inspection of a ship's lifting appliances and the loose cargo gear stored on board a ship. It also requires the marking of a ship's lifting appliances and loose cargo gear, and the carriage of a register of equipment, rigging plan and test certificates for the lifting appliances and gear.
- (b) Further information, including exemptions, can be found at www.maritimenz.govt.nz/Rules

1.2 Legislation

The Health and Safety in Employment Act 1992 (the Act) is the over-arching legislation for health and safety in the workplace and compliance with the Act is mandatory.

The Act is underpinned by a number of Regulations.

The legislation and regulations applicable to this Code are as follows:

- Health and Safety in Employment Act 1992
- Health and Safety in Employment Regulations 1995
- Health and Safety in Employment (Pressure Equipment, Cranes and Passenger Ropeways) Regulations 1999

Extracts are produced in Appendices 1 to 3.

Full copies of the legislation can be obtained from the New Zealand government's legislation website at www.legislation.govt.nz.

1.3 Interpretation

In this Code, the terms 'shall' and 'should' are used. 'Shall' is used where there is a requirement to meet legal obligations. 'Should' is used as a way of indicating the practicable steps the Ministry expects to be taken on a particular matter.

1.4 Definitions

<p>All practicable steps</p>	<p><i>Reference: Section 2A Health and Safety in Employment Act 1992</i></p> <p>'All practicable steps', in relation to achieving any result in any circumstances, means all steps to achieve the result that it is reasonably practicable to take in the circumstances, having regard to:</p> <ul style="list-style-type: none"> • the nature and severity of the harm that may be suffered if the result is not achieved; and • the current state of knowledge about the likelihood that harm of that nature and severity will be suffered if the result is not achieved; and • the current state of knowledge about harm of that nature; and • the current state of knowledge about the means available to achieve the result, and about the likely efficacy of each of those means; and • the availability and cost of each of those means. <p>To avoid doubt, a person required by this Act to take all practicable steps is required to take those steps only in respect of circumstances that the person knows or ought to reasonably know about.</p>
<p>Anchor</p>	<p>Means a designated point for the purpose of attaching a working line, safety line or other fall protection system.</p>
<p>Bight</p>	<p>Means a curved section or loop in a rope or chain.</p>
<p>Chartered professional engineer (CPEng)</p>	<p>Means a person who is registered and holds a current registration certificate under the Chartered Professional Engineers of New Zealand Act 2002.</p> <p>A list of chartered professional engineers can be downloaded from the Institute of Professional Engineers New Zealand (IPENZ) website: www.ipenz.org.nz/ipenz/finding/cpeng/Search/search.cfm</p>
<p>Cheek plate</p>	<p>Cheek plates are attached to crane hook blocks. Otherwise known as weight plates or side plates, cheek plates are fixed to the side of the crane's sheave plates. Cheek plates are commonly used with large capacity cranes to add extra weight to the hook block.</p>
<p>Competent person</p>	<p>Means a person who has acquired, through a combination of qualifications, training or experience, the knowledge and skill to perform the task required.</p>

<p>Confined space</p>	<p><i>Reference: AS 2865: Confined spaces</i></p> <p>Means an enclosed or partially enclosed space that is not intended or designed primarily for human occupancy, within which there is a risk of one or more of the following:</p> <ul style="list-style-type: none"> • An oxygen concentration outside the safe oxygen range. • A concentration of airborne contaminant that may cause impairment, loss of consciousness or asphyxiation. • A concentration of flammable airborne contaminant that may cause injury from fire or explosion. • Engulfment in a stored free-flowing solid or a rising level of liquid that may cause suffocation or drowning.
<p>Construction work</p>	<p><i>Reference: Regulation 2 Health and Safety in Employment Regulations 1995</i></p> <p>Means any work in connection with the alteration, cleaning, construction, demolition, dismantling, erection, installation, maintenance, painting, removal, renewal, or repair of:</p> <ul style="list-style-type: none"> • any building, chimney, edifice, erection, fence, structure, or wall, whether constructed wholly above or below, or partly above and partly below, ground level; and • any aerodrome, cableway, canal, harbour works, motorway, railway, road, or tramway; and • anything having the purpose of drainage, flood control, irrigation or river control; and • any distribution system or network having the purpose of carrying electricity, gas, telecommunications, or water; and • any aqueduct, bridge, culvert, dam, earthwork, pipeline, reclamation, reservoir or viaduct; and • any scaffolding.
<p>Crane</p>	<p><i>Reference: Schedule 1 Health and Safety in Employment (Pressure Equipment, Cranes and Passenger Ropeways) Regulations 1999</i></p> <p>Means a powered device:</p> <ul style="list-style-type: none"> • that is equipped with mechanical means for raising or lowering loads suspended by means of a hook or other load-handling device; and • that can, by the movement of the whole device or of its boom, jib, trolley or other such part, re-position or move suspended loads both vertically and horizontally; and • includes all parts of the crane down to and including the hook or load-handling device, and all chains, rails, ropes, wires, or other devices used to move the hook or load-handling device; and • includes the attachments, fittings, foundations, mountings and supports; but

	<ul style="list-style-type: none"> does not include lifting gear that is not an integral part of the crane.
Design verifier	<p><i>Reference: Schedule 1 Health and Safety in Employment (Pressure Equipment, Cranes and Passenger Ropeways) Regulations 1999</i></p> <p>Means a person who:</p> <ul style="list-style-type: none"> is employed or engaged by an inspection body to carry out the functions referred to in the PECPR Regulations, and is the holder of a relevant certificate of competence.
Dry dock	Means a dock that can be kept dry, or free of water, for shipbuilding or ship maintenance.
Edge protection	<p><i>Reference: Best Practice Guidelines for Working at Height in New Zealand</i></p> <p>Means some form of guardrail or barrier designed to prevent a person reaching or falling over an exposed edge.</p>
Employee	<p><i>Reference: Section 2 Health and Safety in Employment Act 1992</i></p> <p>Subject to sections 3C to 3F [of the Act], means a person of any age employed by an employer to do any work (other than residential work) for hire or reward under a contract of service; and in relation to any employer, means an employee of the employer.</p>
Employer	<p><i>Reference: Section 2 Health and Safety in Employment Act 1992</i></p> <p>Subject to sections 3C to 3F [of the Act] means a person who or that employs any other person to do any work for hire or reward, and, in relation to any employee, means an employer of the employee.</p>
Fall-arrest system	<p><i>Reference: Best Practice Guidelines for Working at Height in New Zealand</i></p> <p>An assembly of interconnected components comprising a harness connected to an anchorage point or anchorage system either directly or by means of a lanyard or pole strap, and whose purpose is to arrest a fall in accordance with the principles and requirements of AS NZS 1891.</p>
Ferrule	Means a metal object used for fastening, joining or reinforcement.

Guardrails	<p><i>Reference: Best Practice Guidelines for Working at Height in New Zealand</i></p> <p>A rail or barrier secured to standards or upright members, at a height above the work platform of 900 mm (minimum) to 1100 mm (maximum) and erected along the exposed sides and ends of working platforms to prevent persons from falling. It includes a lower rail that is fixed to standards midway between the guardrail and the platform. See the SARNZ <i>Best Practice Guidelines for Scaffolding in New Zealand</i>.</p>
Grommet	Means an endless wire rope sling.
Hawser-laid	Means a rope or sling made up of three strands, the fibres (or yarns) of which have been twisted together to make the rope or sling.
Hazard	<p><i>Reference: Section 2 Health and Safety in Employment Act 1992</i></p> <p>Means an activity, arrangement, circumstance, event, occurrence, phenomenon, process, situation, or substance (whether arising or caused within or outside a place of work) that is an actual or potential cause or source of harm; and Includes:</p> <ul style="list-style-type: none"> • a situation where a person’s behaviour may be an actual or potential cause or source of harm to the person or another person; and • without limitation, a situation described in subparagraph (i) resulting from physical or mental fatigue, drugs, alcohol, traumatic shock, or another temporary condition that affects a person’s behaviour.
Inertia reel	Means a self-locking device used to arrest a fall.
ISO	Means the International Standards Organisation.
Lanyard	<p><i>Reference: Best Practice Guidelines for Working at Height in New Zealand</i></p> <p>Means a line used to connect a harness to an anchorage point or static line, usually as part of a lanyard assembly, which includes a personal energy absorber.</p>
LEENZ	<p>Means the Lifting Equipment Engineers New Zealand Incorporated, an organisation formed in 1992 to adopt a common range of Standards for the New Zealand industry and to promote the safe use of lifting equipment.</p> <p>Further information can be found at www.leenz.org/index.html.</p>

Lifting appliance	Means any appliance (except where defined in the <i>Approved Code of Practice for Cranes</i>) capable of being operated by mechanical, manual, or other means to raise or lower a load in a vertical or near vertical plane, and includes any lifting tackle.
Lifting beams	Means a beam which carries loads from two or more points while being supported by one or more different points.
Lifting frame	Means a device made up of more than one lifting beam.
Lifting spreader	Means a device which spreads the lifting ropes and is in compression.
Lifting tackle	Means any sling, shackle, swivel, ring, hook or other appliances, including lifting beams, frames and spreaders, used in connection with a lifting appliance or from the hook of a crane.
Notifiable Work:	<p><i>Reference: Regulation 2 Health and Safety in Employment Regulations 1995</i></p> <p>Any restricted work, as that term is defined in regulation 2(1) of the Health and Safety in Employment (Asbestos) Regulations 1998:</p> <ul style="list-style-type: none"> • any logging operation or tree-felling operation, being an operation that is undertaken for commercial purposes: • any construction work of one or more of the following kinds: <ul style="list-style-type: none"> ○ work in which a risk arises that any person may fall 5 metres or more, other than— <ul style="list-style-type: none"> ▪ work in connection with a residential building up to and including 2 full storeys: ▪ work on overhead telecommunications lines and overhead electric power lines: ▪ work carried out from a ladder only: ▪ maintenance and repair work of a minor or routine nature: ○ the erection or dismantling of scaffolding from which any person may fall 5 metres or more: ○ work using a lifting appliance where the appliance has to lift a mass of 500 kilograms or more a vertical distance of 5 metres or more, other than work using an excavator, a forklift, or a self-propelled mobile crane: ○ work in any pit, shaft, trench, or other excavation in which any person is required to work in a space more than 1.5 metres deep and having a depth greater than the horizontal width at the top: ○ work in any drive, excavation, or heading in which any person is required to work with a ground cover overhead:

	<ul style="list-style-type: none"> ○ work in any excavation in which any face has a vertical height of more than 5 metres and an average slope steeper than a ratio of 1 horizontal to 2 vertical: ○ work in which any explosive is used or in which any explosive is kept on the site for the purpose of being used: ○ work in which any person breathes air that is or has been compressed or a respiratory medium other than air.
Operator	Means a person who operates any plant or equipment.
Reeving	Means to place the rope or webbing sling through a block or eye, or a webbing sling through the eye in the end of the sling.
Rigger/Dogman	<p><i>Reference: Approved Code of Practice for Cranes – Includes the Design, Manufacture, Supply, Safe Operation, Maintenance, and Inspection of Cranes</i></p> <p>Means a person qualified to sling loads and direct the lifting and placing operations of a crane.</p>
Rigging	Means the use of mechanical load-shifting equipment and associated gear to move, place or secure a load including plant, equipment, or members of a building or structure and to ensure the stability of those members, and for the setting up and dismantling of cranes and hoists, other than the setting up of a crane or hoist which only requires the positioning of external outriggers or stabilisers.
Safety net	Means a horizontal system of nets and their supports, as cited in BS EN 1263-1 <i>Industry safety nets: Safety requirements, test methods</i> .
Serious harm	<p><i>Reference: Section 2 and Schedule 1 Health and Safety in Employment Act 1992</i></p> <ul style="list-style-type: none"> • Death. • Any of the following conditions that amounts to or results in permanent loss of bodily function, or temporary severe loss of bodily function: respiratory disease, noise-induced hearing loss, neurological disease, cancer, dermatological disease, communicable disease, musculoskeletal disease, illness caused by exposure to infected material, decompression sickness, poisoning, vision impairment, chemical or hot-metal burn of eye, penetrating wound of eye, bone fracture, laceration, crushing. • Amputation of body part. • Burns requiring referral to a specialist registered medical

	<p>practitioner or specialist outpatient clinic.</p> <ul style="list-style-type: none"> • Loss of consciousness from lack of oxygen. • Loss of consciousness, or acute illness requiring treatment by a registered medical practitioner, from absorption, inhalation, or ingestion, of any substance. • Any harm that causes the person harmed to be hospitalised for a period of 48 hours or more commencing within 7 days of the harm's occurrence.
Sheaves	Sheaves lead the rope over the head of cranes and hoists and are used in pulley systems to gain a mechanical advantage.
Significant hazard	<p><i>Reference: Section 2 Health and Safety in Employment Act 1992</i></p> <p>A hazard that is an actual or potential cause or source of:</p> <ul style="list-style-type: none"> • serious harm; or • harm (being harm that is more than trivial) the severity of whose effects on any person depend (entirely or among other things) on the extent or frequency of the person's exposure to the hazard; or • harm that does not usually occur, or usually is not easily detectable, until a significant time after exposure to the hazard.
Standards	Standards are quoted throughout this code of practice, but another standard may be acceptable if proved to be equivalent. Standards are used not as a restriction but as a means of compliance with the code of practice.
Tag line	Means a rope of suitable strength, construction and length attached with an appropriate recognised bend or hitch to the load, which is used to control the load during lifting or positioning.
Test certificate	Means a certificate issued by an authorised person or authority.
WLL	Means the working load limit, the maximum working load designed by the manufacturer. This term is now used instead of SWL (safe working limit).

PART 2: GENERAL SAFETY AND EQUIPMENT

2.1 General

Lifting and rigging often needs to be carried out at a height where the danger from falling is greater than normal. Safety systems will need to be deployed where this is the case.

2.2 Safety systems

A safety system could include either one or a combination of the following devices:

- guardrails for edge protection
- anchor points and inserts
- fall arrest equipment
- ropes and slings
- lanyards and shock absorbers
- inertia reels
- safety nets.

For further information on working safely at heights, refer to the [Best Practice Guidelines for Working at Height in New Zealand](#).

2.3 Personal safety

Personal protective equipment includes the following (but is not necessarily restricted to):

- a hard hat or safety helmet compliant with AS/NZS 1800* or other appropriate standard
- safety shoes or boots compliant with AS/NZS 2210.1* or other appropriate standard
- close-fitting overalls or clothes
- close-fitting gloves appropriate for the work being undertaken
- ear and eye protection
- appropriate fall protection equipment
- wet weather clothing
- specialist equipment to suit the job at hand
- ultraviolet protection:
 - sunscreen
 - hat
 - suitable clothing
- high-visibility clothing
- respiratory protection suitable for the workplace conditions and hazards.

* Refer to Appendix 5: Reference Documents

2.4 Tools and equipment

When climbing and working at heights, the number of tools and items of equipment carried should be minimal and tools should be secured to a lanyard.

2.5 Further information

Further information on working safely at heights is available from the Ministry of Business, Innovation and Employment (refer to *Appendix 5: Reference Documents*).

PART 3: EQUIPMENT AND APPROPRIATE SAFETY FACTORS

3.1 Identification

Every lifting appliance and item of loose gear shall be clearly and permanently marked with its WLL by stamping, or where this is impracticable or not recommended, by other suitable means. Also, a unique identifying numbering system to clearly identify individual items should be used.

3.2 Factors of safety

The factor of safety is the ratio between the minimum breaking load and the working load limit.

The factor of safety for steel wire rope must not be less than 6:1 for web slings and round slings.

The factor of safety for other steel wire rope must not be less than 5:1.

Note: for special-purpose ropes, check the manufacturer's specifications.

The factor of safety for chain and associated hardware must not be less than 4:1, and the chain for slings shall be to a suitable ISO standard or equivalent grade endorsed for lifting purposes. All chains and fittings should be of the same grade and not be mixed. Grade 80 and Grade 8 are considered to be compatible.

Note: If a higher grade chain or component is used in a sling assembly, the sling must be rated to the lowest WLL of the chain or components being used.

Only grades of chain complying with BS EN 818-7* or equivalent can be used with lifting.

For all other grades above Grade 80, for example Grade 85, Grade 95, refer to the manufacturers' WLL charts.

The factor of safety for fibre ropes varies depending on the diameter, and must be as per BS EN 1492-4*, or refer to tables 4 and 5.

3.3 Flat web and round slings

Webbing slings are manufactured to comply with AS 1353.1* or equivalent. All slings shall have a minimum 6:1 safety factor.

Table 2 illustrates six basic sling types, with a minimum WLL 6:1 safety factor. The WLL (see table 1) is quoted in kilograms for vertical, choker, or basket applications in single or two-ply construction.

* Refer to Appendix 5: Reference Documents

Round slings comprise of a hank of polyester yarn of one or more strands wound together continuously to form an endless sling protected by an outer sleeve.

The slings have woven stripes in the outer casing, each of which represents a one tonne working load limit. They may also be colour coded.

The combination of woven stripes with recognised colour codes enables the user to more easily recognise the capacity of the sling even when it is soiled.

Care should be taken when inspecting web slings utilising wear sleeves and particularly in the case where the full length of the sling is not visible.

Webbing slings should be inspected for:

- cuts or damage to webbing
- damage to eyes
- damage to metal eyes or other end fittings
- chemical damage.

Table 1: Web slings: WLL capacity (WLL 6:1 capacity rating in tonnes)







Nominal sling width	No. of Plies	Single-leg slings				Endless slings			
									
38mm	One	0.75	0.60	1.05	1.50	1.50	1.20	2.10	3.00
	Two	1.50	1.20	2.10	3.00	3.00	2.40	4.20	6.00
50mm	One	1.00	0.80	1.40	2.00	2.00	1.60	2.80	4.00
	Two	2.00	1.60	2.80	4.00	4.00	3.20	5.60	8.00
75mm	One	1.50	1.20	2.10	3.00	3.00	2.40	4.20	6.00
	Two	3.00	2.40	4.20	6.00	6.00	4.80	8.40	12.00
100mm	One	2.00	1.60	2.80	4.00	4.00	3.20	5.60	8.00
	Two	4.00	3.20	5.60	8.00	8.00	6.40	11.20	16.00
150mm	One	3.00	2.40	4.20	6.00	6.00	4.80	8.40	12.00
	Two	6.00	4.80	8.40	12.00	12.00	9.60	16.80	24.00
200mm	One	4.00	3.20	5.60	8.00	8.00	6.40	11.20	16.00
	Two	8.00	6.40	11.20	16.00	16.00	12.80	22.40	32.00
300mm	One	6.00	4.80	8.40	12.00				
	Two	12.00	9.60	16.80	24.00				

Table 2: Types of slings

Figure	Drawing	Description
Figure 1: Flat eye sling		A flat eye sling for vertical or flat use.
Figure 2: Reversed eye sling		A reversed eye sling for choker hitches or where proper alignment of the load is needed – the eyes being in the same plane as the webbing.
Figure 3: Plain dee sling		These slings have the same application as eye slings, but with metal dees. This sling has two plain dees.
Figure 4: Dee sling with choker		This sling has a metal dee in choker form at the end.
Figure 5: Endless sling		The endless sling, or loop sling, is most suitable for bulky and awkward loads where stability and easy contour are important factors.
Figure 6: Wide load loop sling		Wide load loop slings are an extension of the sling. The use of the wide load pad gives the greatest possible bearing surface for delicate loads.
Figure 7: Reduced eye sling		Reduced eye slings for use with small hooks.

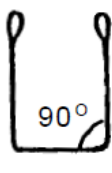
Table 3: Colour coding and lifting capacity of synthetic slings (tonnes)



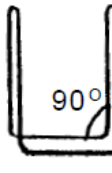

Colour	Tonnes			
	Vertical	Choke	Basket	90 ° Basket
Violet	1.0	0.80	1.40	2.0
Green	2.0	1.60	2.80	4.0
Yellow	3.0	2.40	4.20	6.0
Orange*	4.0	3.20	5.60	8.0
Red	5.0	4.00	7.00	10.0
Brown	6.0	4.80	8.40	12.0
Blue	8.0	6.40	11.20	16.0
Grey**	12.0	9.60	16.80	24.0

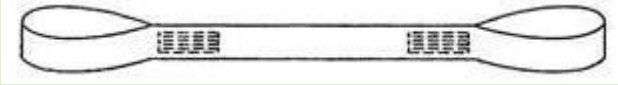
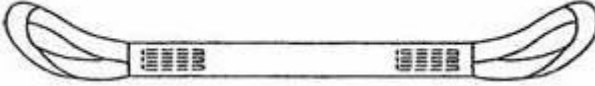
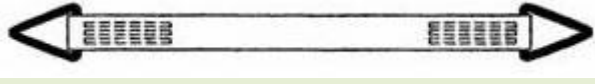
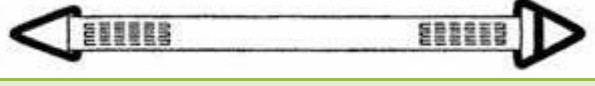
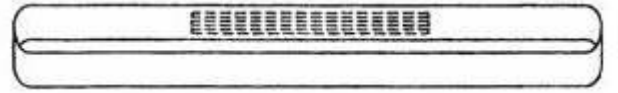
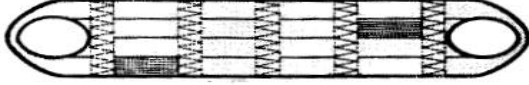
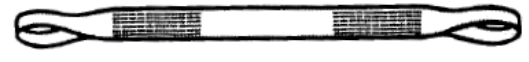
Note: Other colours may be accepted with supporting certificates.

- * From Europe, grey is rated four tonnes and orange is rated 12 tonnes for vertical lifts.
- ** From Australia, grey is rated four tonnes and orange is rated 10 tonnes for vertical lifts.

3.4 Manilla rope

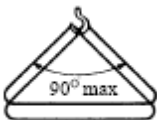
Table 4: Maximum WLLs for slings in three-strand hawser-laid constructions for endless sling configurations

Nominal diameter of rope (three-strand hawser laid)	Maximum working load limit (Note: "M" = Mode Factor: this is a constant for the particular layout of the sling and when multiplied by the WLL of the single leg gives the maximum WLL of the sling)			
	Straight pull M = 2.0 	Choke hitch M = 1.6 	Basket hitch M = 2.8 	Basket hitch parallel M = 4.0 
mm	t	t	t	t
12	0.250	0.200	0.350	0.500
14	0.350	0.280	0.490	0.700
16	0.550	0.440	0.770	1.1
18	0.700	0.560	0.980	1.4
20	0.976	0.781	1.4	2.0
24	1.5	1.2	2.1	3.1
28	2.2	1.8	3.1	4.4
32	3.0	2.4	4.2	6.0
36	3.8	3.0	5.3	7.6
40	5.0	4.0	7.0	10.0
44	6.0	4.8	8.4	12.0
48	7.6	6.1	10.6	15.2





Note: Slings having working loads below one tonne are usually marked in kilograms.

One tonne = 1000 kilograms.

Further information is available in the LEENZ Code of Practice*.

* Refer to Appendix 5: Reference Documents

Table 5: Maximum WLLs for slings made of Grade 1 Manila ropes in three-strand hawser-laid constructions for single strop configurations

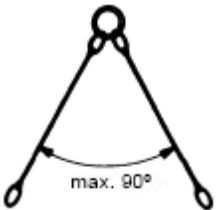
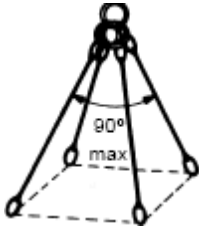
Nominal diameter of rope (three-strand hawser laid)	Maximum working load limit					
	Straight pull M = 1.0	Choke hitch M = 0.8	Basket hitch 90° M = 1.4	Basket hitch parallel M = 2.0	Two-legged M = 1.4	Four-legged M = 1.4
						
mm	t	t	t	t	t	t
12	0.125	0.100	0.175	0.250	0.175	0.250
14	0.175	0.140	0.245	0.350	0.245	0.350
16	0.275	0.220	0.385	0.550	0.385	0.550
18	0.350	0.280	0.490	0.700	0.490	0.700
20	0.488	0.390	0.683	0.976	0.683	0.976
24	0.763	0.610	1.1	1.5	1.1	1.5
28	1.1	0.880	1.5	2.2	1.5	2.2
32	1.5	1.2	2.1	3.0	2.1	3.0
36	1.9	1.5	2.7	3.8	2.7	3.8
40	2.5	2.0	3.5	5.0	3.5	5.0
44	3.0	2.4	4.2	6.0	4.2	6.0
48	3.8	3.0	5.3	7.6	5.3	7.6

Note: Slings having working loads below one tonne are usually marked in kilograms. One tonne = 1000 kilograms.

3.5 Chain and chain slings

Refer to BS EN 818-4 or equivalent for chain and ISO 7593 or equivalent for chain sling, and to tables 6 and 7 of this Code. Further information is available in the LEENZ Code of Practice.



The safety factor for chain slings is 4:1.

Chain slings should be inspected for:

- corrosion
- worn, stretched or deformed links
- worn, stretched or deformed hooks and fittings
- wear on load pins and to ensure retainers are installed correctly
- wear on chain links to be no more than 10% of the original chain thickness. If more than 10%, the chain must be replaced.

3.6 Uniform method: grade 8

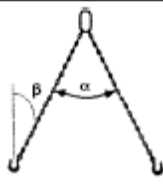
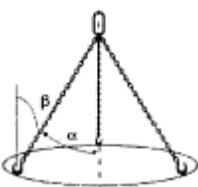
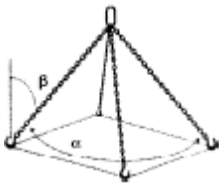

Table 6: WLLs: General purpose Grade 80 chain slings: uniform load method operating in accordance with EN818-4 (**Note:** for higher grades, refer to manufacturers' specifications)

Chain size (mm)	Single-leg	Two-leg		Three-leg	Four-leg	Choked sling	Endless	Min dia of pin/lug or lifting member
		Angle	Angle					
								
	0° t	β up to 45° α 0-90° t	β 45-60° α 90-120° t	β up to 45° α 0-90° t	β 45-60° α 90-120° t	0-90° t	90-120° t	
6	1.12	1.60	1.12	2.38	1.68	0.89	1.80	
7	1.50	2.12	1.50	3.18	2.25	1.20	2.50	30
8	2.00	2.0	2.80	4.24	3.00	1.60	3.15	
10	3.15	4.25	3.45	6.68	4.73	2.52	5.00	85
13	5.30	7.50	5.30	11.20	7.95	4.24	8.50	110
16	8.00	11.3	8.00	17.00	12.00	6.40	12.50	135
19	11.20	16.00	11.20	23.80	16.80	8.96	18.00	160
20	12.50	17.70	12.50	26.50	18.80	10.00	20.00	
22	15.00	21.20	15.00	31.80	22.50	12.00	23.60	
23	16.00	22.60	16.00	33.90	24.00	12.80	26.50	195
26	21.20	30.00	21.20	45.00	31.80	16.96	33.50	220
32	31.50	45.00	31.50	66.80	47.30	25.20	50.00	270

Note: If a multiple-leg choker is being used, reduce WLL by 20% if oblong or square object and 25% if round object.

3.7 Trigonometric method: grade 80

Table 7: Special-purpose slings: trigonometric method of rating (**Note:** for higher grades, refer to manufacturers' specifications)

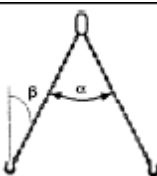
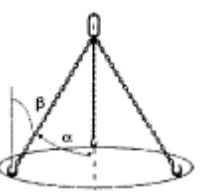
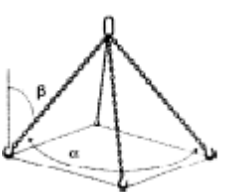
Chain size (mm)	Endless	Single-leg	Two-leg				Three-leg				Four-leg				Min Dia of Pin mm
			α at 30° t	α at 60° t	α at 90° t	α at 120° t	β at 15° t	β at 30° t	β at 45° t	β at 60° t	α at 30° t	α at 60° t	α at 90° t	α at 120° t	
															
6	1.6		1.9	1.7	1.4	1	2.9	2.5	2.1	1.5	3.9	3.5	2.8	2	
7	1.79	1.12	2.13	1.90	1.57	1.12	3.25	2.80	2.35	1.68	4.37	3.92	3.14	2.24	
8	2.40	1.50	2.90	2.60	2.10	1.50	4.35	3.75	3.15	2.25	5.85	5.25	4.20	3.00	30
10	3.20	2.00	3.80	3.40	2.80	2.00	5.80	5.00	4.20	3.00	7.80	7.00	5.60	4.00	
13	5.04	3.15	5.99	5.36	4.41	3.15	9.10	7.88	6.62	4.73	12.29	11.03	8.82	6.40	85
16	8.48	5.30	10.20	9.20	7.50	5.30	15.40	13.25	11.13	7.95	20.67	18.55	14.84	10.60	110
19	12.80	8.00	15.50	13.90	11.20	8.00	23.20	20.00	16.80	12.00	31.20	28.00	22.40	16.00	135
20	17.92	11.20	21.60	19.40	15.80	11.20	32.50	28.00	23.52	16.80	43.68	39.20	31.36	22.40	160
22	20.00	12.50	24.10	21.70	17.70	12.50	36.20	31.25	26.25	18.75	48.75	43.75	35.00	25.00	
23	24.00	15.00	29.00	26.00	21.20	15.00	43.50	37.50	31.50	22.50	58.50	43.75	42.00	30.00	
26	25.60	16.00	30.90	27.70	22.60	16.00	46.40	40.00	33.60	24.00	62.40	56.00	44.80	32.00	195
32	33.92	21.20	41.00	36.70	30.00	21.20	61.40	53.00	44.52	31.80	82.68	74.20	59.36	42.40	220
32	50.40	31.50	60.90	54.60	44.50	31.50	91.30	66.15	67.20	47.25	122.85	110.25	88.20	63.00	270

Note: If a multiple-leg choker is being used, reduce WLL by 20%.

3.8 Wire rope

Refer to BS 302-5* or an equivalent standard, and to tables 8 and 9 for WLLs. For wire ropes not covered by these tables, the WLL is 5:1, based on the manufacturer's certificate. Further information may be available in the LEENZ Code of Practice, or as stated by the manufacturer.

Refer to ISO 4309* or equivalent for protocols for discarding wire ropes.

Wire rope shall not be used around a diameter less than:

- for a soft eye single-leg sling: 2 x rope diameter
- for a grommet or basket: 4 x rope diameter.

3.9 Components

The factor of safety of any sling components used in lifting gear and not manufactured to a standard shall be rated in accordance with the equipment it is to be used with, for example:

- webbing sling metal components: 4:1
- wire rope: 5:1
- chain: 4:1.

A sample shall either be tested to destruction or the relevant engineering calculations provided by a competent person, and a proof load test carried out in accordance with the above safety factors.

Table 8: WLLs for slings constructed from wire ropes with fibre cores (1770 tensile strength steel) 6 x 19 to 6 x 41 (excluding 6 x 24)

Rope diameter	Working Load Limit (WLL)									
	Single-leg slings		Multi-leg slings							
	Single, terminated by ferrules or splices	Single, terminated by grommet	Leg angle $0^\circ < \delta - 90^\circ$ $0^\circ < \beta - 45^\circ$				Leg angle $90^\circ < \delta - 120^\circ$ $45^\circ < \beta - 20^\circ$			
			Two-leg		Three- or four-leg		Two-leg		Three- or four-leg	
Single			Grommet	Single	Grommet	Single	Grommet	Single	Grommet	
A	B	C	D	E	F	G	H	I	J	K
mm	t	t	t	t	t	t	t	T	t	t
5	0.276	0.414	0.386	0.579	0.579	0.869	0.276	0.414	0.414	0.621
6	0.398	0.597	0.557	0.836	0.836	1.2	0.398	0.597	0.597	0.895
7	0.542	0.813	0.759	1.1	1.1	1.7	0.542	0.813	0.813	1.2
8	0.762	1.1	1.0	1.5	1.6	2.3	0.762	1.1	1.1	1.6
9	0.962	1.4	1.3	1.9	2.0	2.9	0.962	1.4	1.4	2.1
10	1.2	1.8	1.7	2.5	2.5	3.8	1.2	1.8	1.8	2.7
11	1.4	2.1	1.9	2.9	2.9	4.4	1.4	2.1	2.1	3.1
12	1.7	2.5	2.4	3.5	3.5	5.2	1.7	2.5	2.5	3.7
13	2.0	3.0	2.8	4.2	4.2	6.3	2.0	3.0	3.0	4.5
14	2.3	3.5	3.2	4.8	4.8	7.3	2.3	3.5	3.4	5.2
16	3.0	4.5	4.2	6.3	6.3	9.4	3.0	4.5	4.5	6.7
18	3.8	5.7	5.3	8.0	8.0	11.9	3.8	5.7	5.7	8.5
19	4.3	6.4	6.0	8.9	9.0	13.4	4.3	6.4	6.4	9.6
20	4.7	7.1	6.6	9.9	9.8	14.9	4.7	7.1	7.0	10.6
22	5.7	8.6	8.0	12.0	11.9	18.0	5.7	8.6	8.5	12.9
24	6.8	10.2	9.5	14.3	14.3	21.4	6.8	10.2	10.2	15.3
26	8.0	12.0	11.0	16.8	18.6	25.2	8.0	12.0	12.0	18.0
28	9.3	14.0	13.0	19.5	19.5	29.4	9.3	14.0	13.9	21.0
32	12.1	18.2	16.9	25.4	25.4	38.2	12.1	18.2	18.1	27.3
35	14.5	21.8.1	20.3	30.4	30.4	45.8	14.5	21.8	21.7	32.7
36	15.4	23.1	21.5	32.3	32.3	48.5	15.4	23.1	23.1	34.6
38	17.1	25.7	23.9	35.9	35.9	53.9	17.1	25.7	25.6	38.5
40	19.0	28.5	26.6	39.9	59.8	59.8	19.0	28.5	28.5	42.7

Table 9: WLLs for slings constructed from wire rope with steel cores (1770 tensile strength steel) 6 x 19 to 6 x 41 (excluding 6 x 24)

Rope diameter	Working Load Limit (WLL)				
	Single-leg slings	Multi-leg slings			
	Single, terminated by ferrules or splices	Leg angle $0^\circ < \delta - 90^\circ$ $0^\circ < \beta < 45^\circ$		Leg angle $90^\circ < \delta - 120^\circ$ $45^\circ < \beta - 60^\circ$	
Two -leg: Single-part leg		Three- or four-leg: single part leg	Two-leg: Single part leg	Four- leg: single-part leg	
A	L	M	N	P	R
mm	t	t	t	t	t
8	0.822*	1.1	1.7	0.822*	1.2
9	1.0	1.4	2.1	1.0	1.5
10	1.3	1.8	2.7	1.3	1.9
11	1.5	2.1	3.1	1.5	2.2
12	1.8	2.5	3.8	1.8	2.7
13	2.1	2.9	4.4	2.1	3.1
14	2.5	3.5	5.2	2.4	3.7
16	3.3	4.6	6.9	3.3	4.9
18	4.1	5.7	8.6	4.1	6.1
19	4.6	6.4	9.6	4.6	6.9
20	5.1	7.1	10.7	5.1	7.6
22	6.2	8.7	13.0	6.2	9.3
24	7.4	10.3	15.5	7.4	11.1
26	8.6	12.0	18.0	8.6	12.9
28	10.0	14.0	21.0	10.0	15.0
32	13.1	18.3	27.5	13.1	19.6
35	15.7	22.0	33.0	15.7	23.5
36	16.6	23.2	34.8	16.6	24.9
38	18.5	25.9	38.8	18.5	27.7
40	20.6	28.8	43.2	20.6	30.9

* WLLs of less than 1 tonne are normally cited in kilograms. Refer to BS 302-5* for further details.

* Refer to Appendix 5: Reference Documents

PART 4: ROPE SPLICES

4.1 Fibre rope

Most common splices, whether in natural fibre or synthetic fibre, are:

- eye splice, soft eye
- eye splice with thimble
- long splice
- short splice.

Rope protrusion should be one rope diameter or in accordance with the manufacturer's specifications or to accepted industry standards.

Eye splices in natural fibre ropes must have a minimum of four full tucks against the lay of the rope or as per industry requirements.

Eye splices in synthetic fibre ropes must have five full tucks against the lay of the rope or as per industry requirements.

4.2 Wire rope

There are various ways of forming eye splices on wire rope for lifting purposes. The following are examples:

- manual soft eye, to accepted industry standards
- manual hard eye (with thimble), to accepted industry standards
- mechanical soft eye (ferrule), in accordance with the manufacturer's specifications
- mechanical hard eye (thimble and ferrule), in accordance with manufacturer's specifications.

Note 1: The dead end of the wire rope must protrude past the ferrule by one rope diameter, unless it is made to a specific design.

Note 2: There are variable de-rating values depending on the splice configuration used.

Wire ropes should be inspected for:

- broken wires
- kinks and deformation
- corrosion
- damage to terminations
- excessive wear.

For more details, refer to ISO 4309*.

4.3 Wire rope thimbles

The nominal size of a thimble is that of the rope with which it is to be used. Refer to BS EN 13411-1* or equivalent.

* Refer to Appendix 5: Reference Documents

4.4 Wire rope (bulldog) grips

Do not use wire rope (bulldog) grips on any load-hoisting rope. Wire rope grips are only suitable for forming an eye on stays or guys. Load-hoisting gives alternating load/tensions in the wire rope, and this alternating load allows the wire rope to stretch/narrow and compress/thicken as the load is applied or released. Movement in the wire rope could allow movement in the grip and allow the wire rope to come loose and pull out of the grip.

Wire rope (bulldog) grips must comply with DIN 1142* or equivalent standard as per the drawings below.

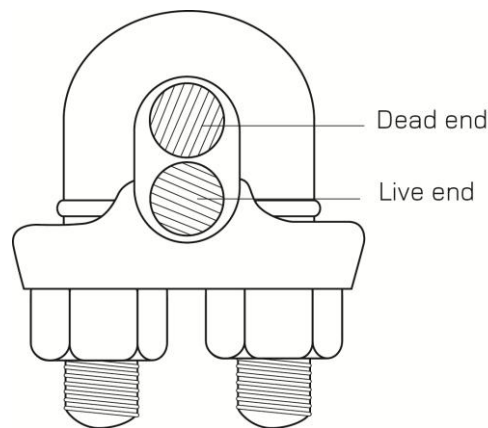

Figure 8: Wire rope (bulldog) grip

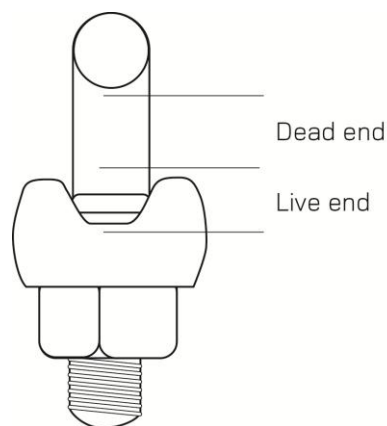

Figure 9: Wire rope (bulldog) grip

* Refer to Appendix 5: Reference Documents

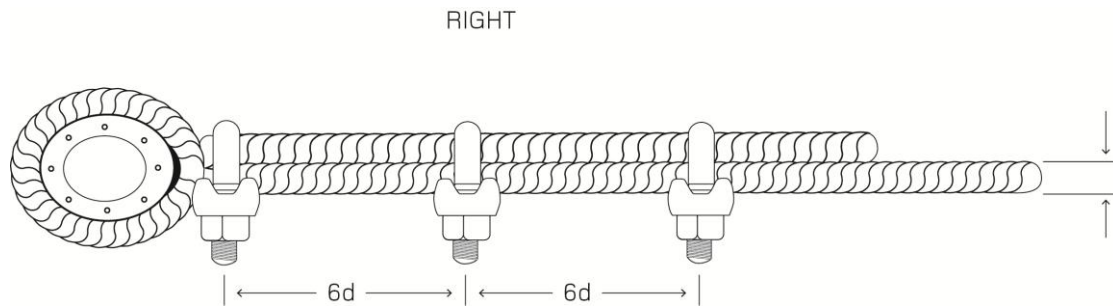

Figure 10: Correct method of using bulldog grips to form an eye

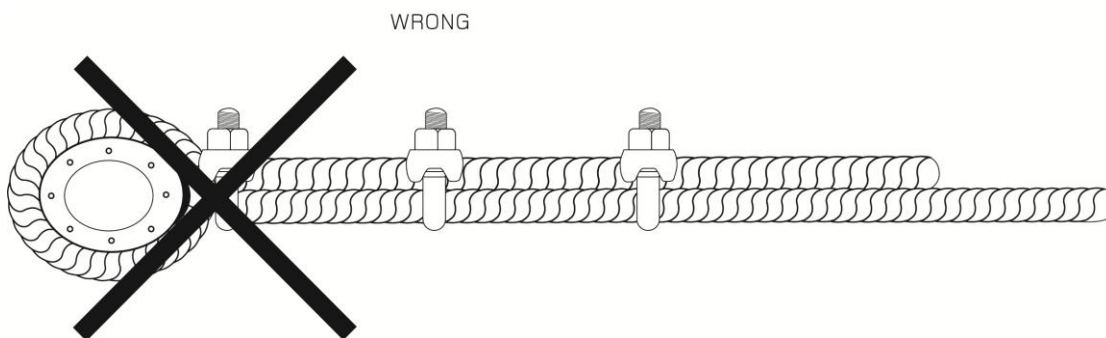

Figure 11: Incorrect method of using bulldog grips

Table 10: Wire rope grips to DIN 1142

Size nominal diameter mm	Required number of wire rope grips to attain 85% of rope minimum breaking load	Required tightening torque to obtain required efficiency Newton metres
5.0	3.0	2.0
6.5	3.0	3.5
8.0	4.0	6.0
10.0	4.0	9.0
13.0	4.0	33.0
16.0	4.0	49.0
19.0	4.0	68.0
22.0	5.0	107.0
26.0	5.0	147.0
30.0	6.0	212.0
34.0	6.0	296.0
40.0	6.0	363.0

- Drop forged
- Material: high tensile steel
- Finish: hot-dipped galvanised

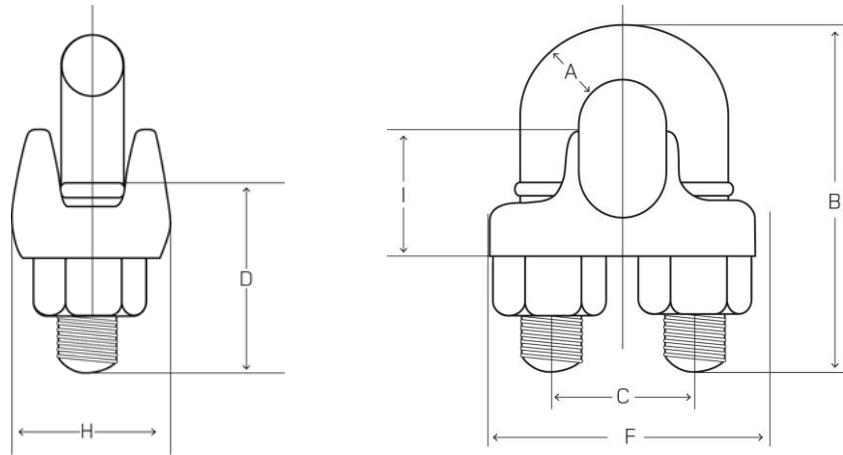

Figure 12: The measurements featured in these diagrams relate to table 11.

Table 11: Wire rope grips - federal specification FF-C-450*

Rope Diameter	Bow Diameter	Bow Length	Bolt Centres	Thread Length	Base Length	Base Thickness	Base Height
(In)	A (mm)	B (mm)	C (mm)	D (mm)	F (mm)	H (mm)	I (mm)
5/16	10	45	22	19	43	33	18
3/8	11	49	26	19	49	42	25
7/16	12	60	30	25	58	46	26
1/2	13	61	30	26	58	48	27
5/8	14	74	33	32	64	52	33
3/4	16	86	38	37	72	57	37
7/8	19	98	45	40	80	62	40
1-0	19	108	48	46	88	67	44
1-1/8	19	117	51	51	91	72	48
1-1/4	22	130	59	54	105	79	56
1-3/8	22	140	60	59	108	79	58
1-1/2	22	147	66	60	112	86	64
1-5/8	26	161	70	67	121	92	67
1-3/4	29	175	78	74	134	97	78
2-0	32	195	86	78	152	113	87

Note: Imperial measurements are used in the first column.

* Refer to Appendix 5: Reference Documents

Table 12: Required tightening torque and minimum number of FF-C-450 grips to attain 80% of rope minimum breaking load

Wire Rope Diameter (In)	Minimum Number of Grips	Torque Value (Ft. Lbs)	Wire Rope Diameter (In)	Minimum Number of Grips	Torque Value (Ft. Lbs)
5/16	2	30	1-1/8	6	225
3/8	2	45	1-1/4	7	360
1/2	3	65	1-3/8	7	360
5/8	3	95	1-1/2	8	360
3/4	4	130	1-5/8	8	430
7/8	4	225	1-3/4	8	590
1-0	5	225	2-0	8	750

Note: Imperial measurements are used in the first column.

PART 5: FITTINGS, SHEAVES AND BLOCKS

5.1 Wedge-type rope sockets

The wedge socket must be properly set up as per the relevant standard BS 7166* or equivalent. Protruding rope shall be a length of six times the diameter of the rope.

Wedge-type rope sockets should be inspected for damage to the rope, wedge and socket.

The wedge should be removed with a pin punch.

The following three drawings demonstrate correct methods of fitting rope to the wedge and the use of rope grips:

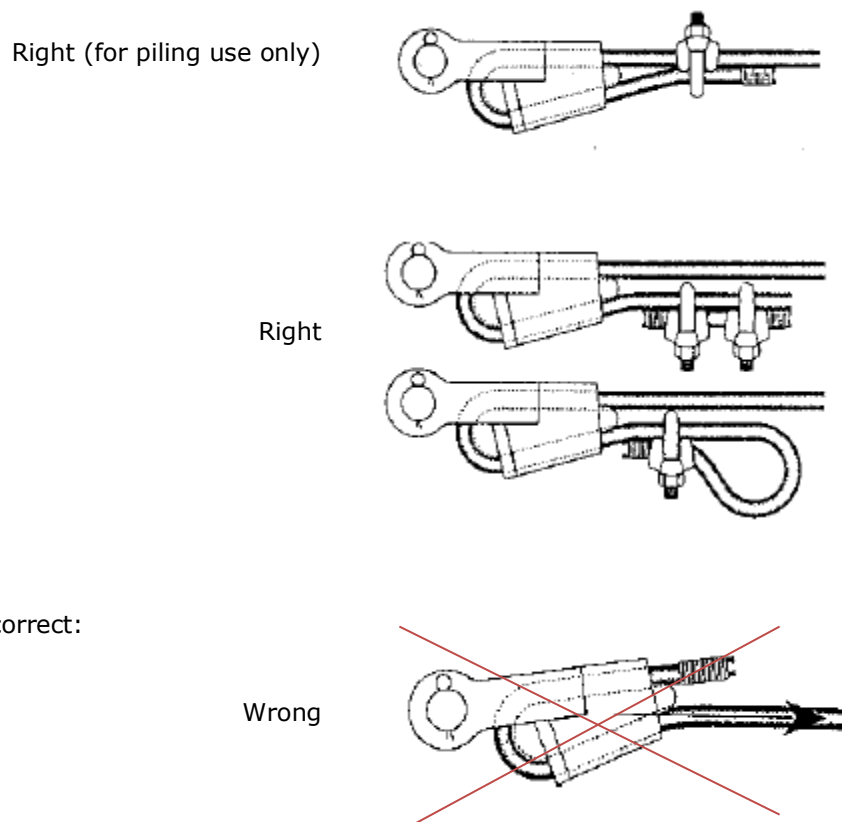

Figure 13: Wedge-type rope sockets

5.2 Rings

Rings for attaching single- and multi-leg slings onto lifting hooks must be of sufficient size and strength to ensure that the safe working capacity of the sling is in no way impaired. Any attaching of slings to rings must ensure that both can move freely on each

* Refer to Appendix 5: Reference Documents

other, and that no undue wear or distortion results in either component. Refer to BS 3458* or equivalent.

5.3 Shackles

Shackles may be made of high-tensile steel or alloy steel. Refer to Federal Specification RR-C-271* or equivalent. Also refer to the Load Chart (table 13).

Shackles used for hoisting purposes must be marked with the WLL.

Shackles should be inspected for:

- mechanical damage to pin or body
- correct tensile pin fitted
- correct pin length
- wear.

5.3.1 Alloy hi-load standard shackles

Material: Body and pin high tensile steel, quenched and tempered.

Safety factor: six times the WLL = minimum breaking strength.

Finish: galvanised.

Standard: US Federal Specification RR-C-271 or equivalent.

* Refer to Appendix 5: Reference Documents

Table 13: US Federal Specification RR-C-271

WLL	Diameter Bow	Diameter Pin	Inside Width	Inside Length		Width of Bow	Approximate Weight Each	
	D	d	a	C	C	2r	Kgs	
Metric tones	mm	mm	mm	mm	mm	mm	Screw Pin	Safety Pin
0.33	5	6	10.0		22	16	0.02	
0.50	6	8	12.0		29	20	0.06	0.07
0.75	8	10	13.5	27	32	21	0.11	0.13
1.00	10	11	16.0	31	36	26	0.15	0.17
1.50	11	13	18.0	37	43	29	0.21	0.25
2.00	13	16	22.0	43	51	32	0.37	0.44
3.25	16	19	27.0	51	64	43	0.65	0.79
4.75	19	22	31.0	59	76	51	1.06	1.26
6.50	22	25	36.0	73	83	58	1.56	1.88
8.50	25	28	43.0	85	95	68	2.32	2.78
9.50	28	32	47.0	90	108	75	3.28	3.87
12.00	32	35	51.0	94	115	83	4.51	5.26
13.50	35	38	57.0	115	133	92	5.93	6.94
17.00	38	42	60.0	127	146	99	7.89	8.79
25.00	45	50	74.0	149	178	126	13.40	14.99
35.00	50	57	83.0	171	197	146	18.85	20.65
42.50	57	65	95.0	190	222	160	26.06	29.01
55.00	65	70	105.0	203	254	185	37.86	41.05
85.00	75	80	127.0	230	330	190	58.68	62.24
120.00	89	95	146.0	267	381	238		110.00

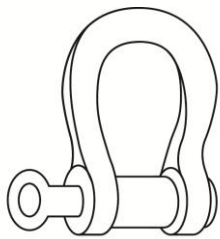

BOW SHACKLE WITH SCREW PIN

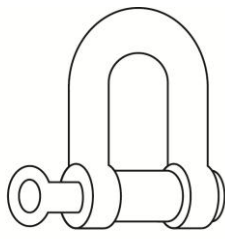

DEE SHACKLE WITH SCREW PIN

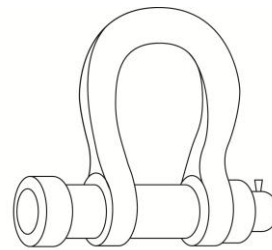

BOW SAFETY WITH ANCHOR SHACKLE

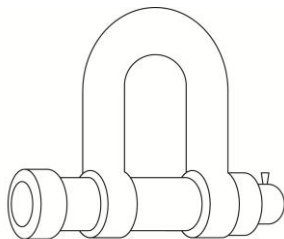

DEE SAFETY WITH ANCHOR SHACKLE

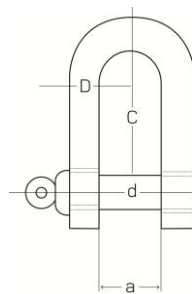

DEE SHACKLE

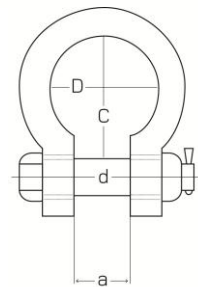

BOW SHACKLE

Table 14: Large Dee shackles to US Federal Specification RR-C-271

WLL Tonnes	mm d	mm D	mm a	mm C	Weight Each Kg
0.25	6	10	13	25	0.11
0.50	10	13	19	38	0.17
0.75	13	16	29	54	0.35
1.50	16	19	32	64	0.66
2.00	19	22	38	73	1.02
3.00	22	25	44	83	1.57
3.75	25	28	51	95	2.30
5.00	28	32	54	105	3.20
6.00	32	35	60	114	4.30
7.00	35	38	67	127	5.40
9.50	38	45	70	137	6.80
11.25	42	48	76	146	8.70
13.00	45	51	83	156	11.00
14.25	48	54	92	178	14.30
16.25	51	57	98	187	20.00
18.00	54	60	105	197	26.38
20.00	57	64	108	210	28.27
25.00	64	73	121	235	35.00
30.00	70	79	133	260	49.03
35.00	76	86	146	279	63.56
40.00	79	89	149	292	71.73
50.00	89	102	171	330	101.24
65.00	102	114	191	375	150.73
80.00	114	127	219	419	214.74

Finish: Self-colour or galvanised.

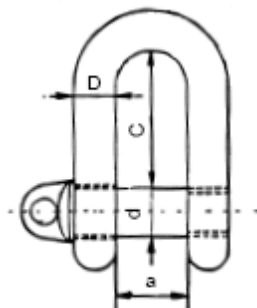

Figure 14: Large dee shackle

5.4 Rigging screws and turnbuckles

Rigging screws and turnbuckles should conform to BS 4429* or equivalent.

Rigging screws and turnbuckles should be inspected for:

- thread damage and thread engaged to a full length of threaded body
- deformation
- corrosion.

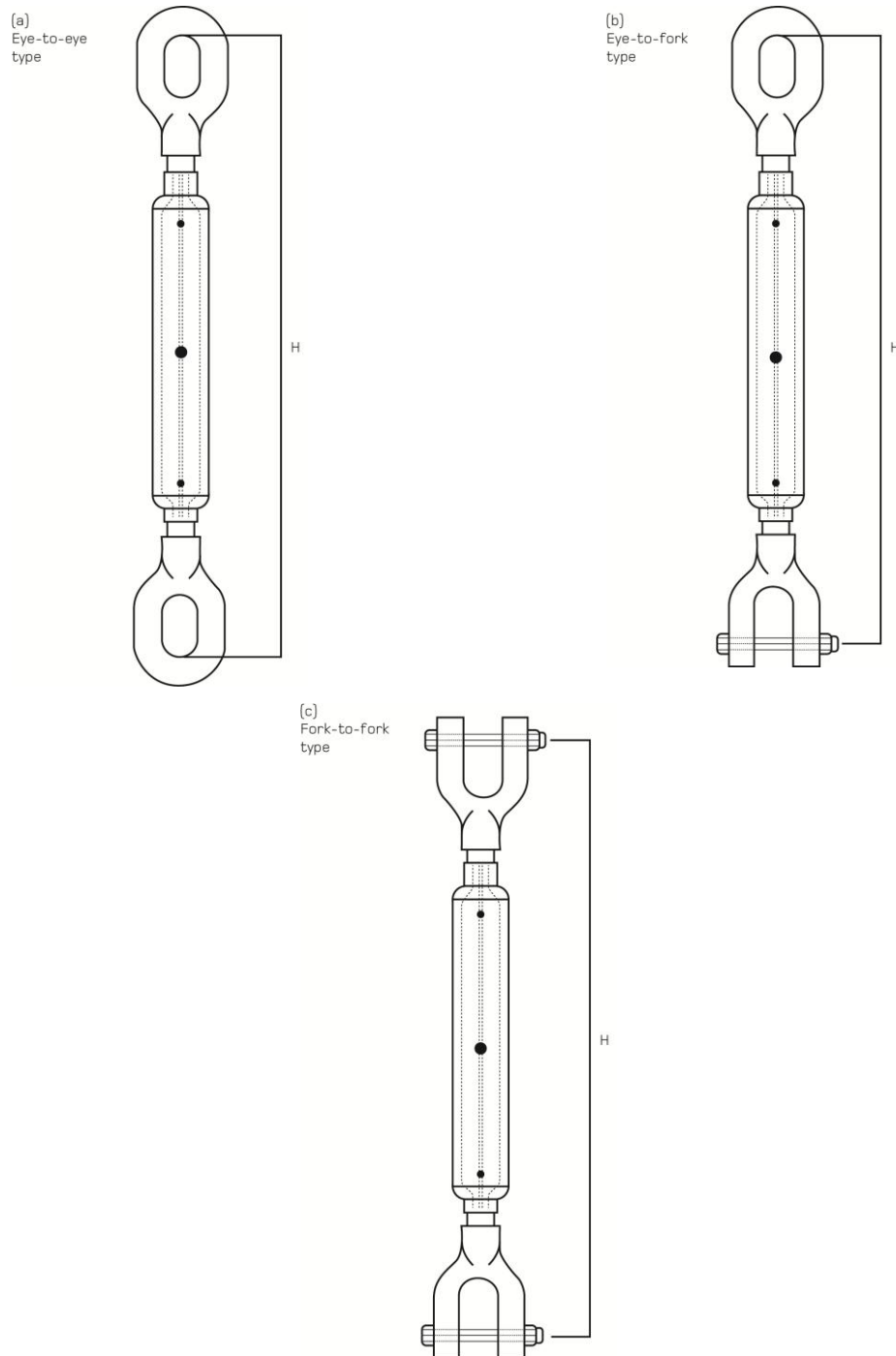

Figure 15: Types of rigging screw

* Refer to Appendix 5: Reference Documents

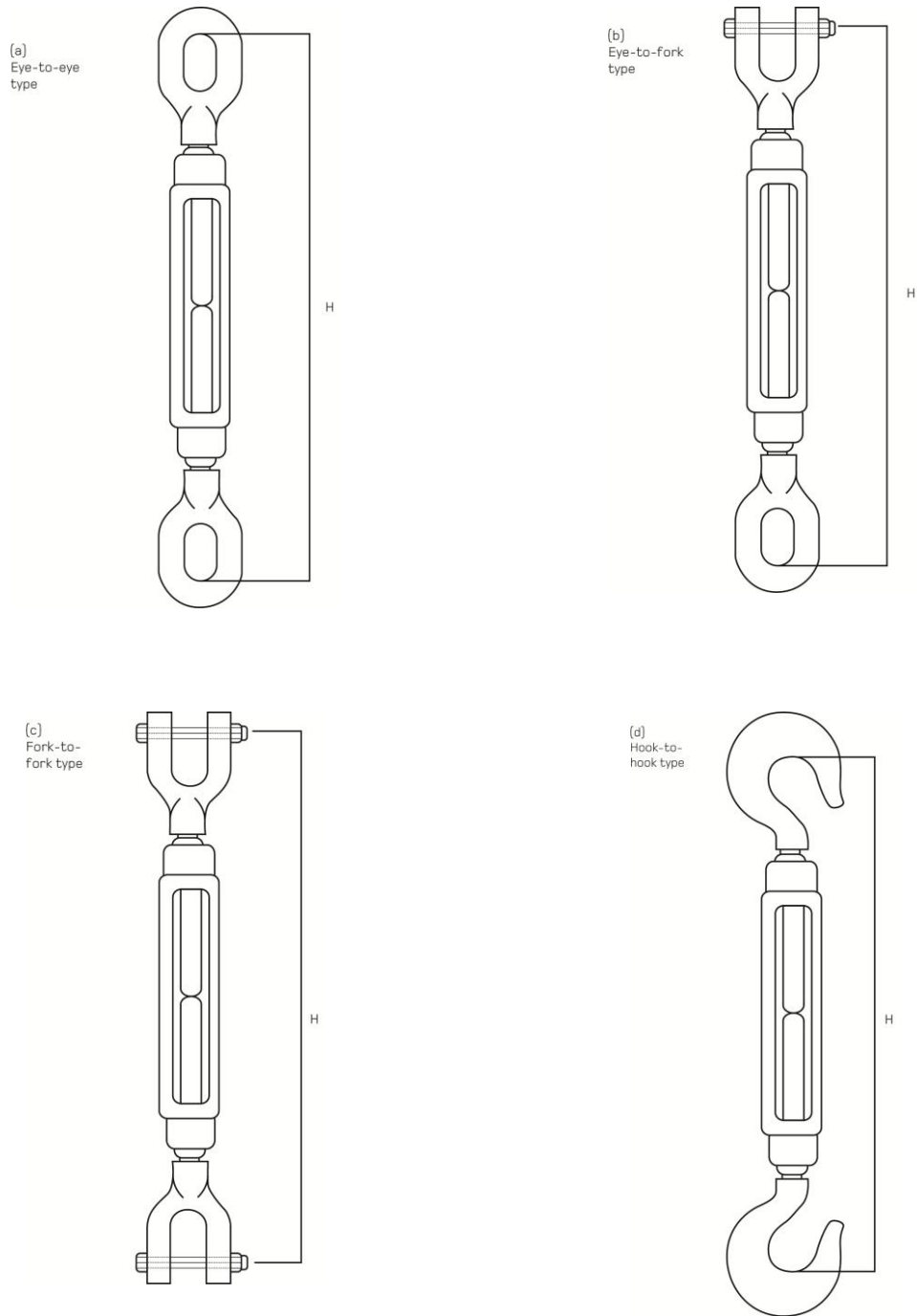

Figure 16: Types of turnbuckle

Table 15: WLLs for rigging screws and turnbuckles to BS 4429*

Thread Diameter (A)	Working load limit (WLL)	Thread Diameter (A)	Working load limit (WLL)
mm	tonnes	mm	tonnes
8	0.2	39	6.0
10	0.3	42	7.5
12	0.5	48	10.0
16	0.75	56	15.0
20	1.25	64	20.0
22	2.0	72	25.0
27	3.0	76	30.0
30	4.0	85	40.0
33	5.0	100	50.0

5.5 Snatch, sheave and cargo blocks

Blocks should comply with the relevant standards:

- BS EN 13157 *Cranes. Safety. Hand-powered cranes.*
- AS 1418.2 *Cranes (including hoists and winches) – Serial hoists and winches.*
- BS MA 47: *Code of practice for ships' cargo blocks*, or equivalent, and tested in accordance with the relevant standard.

The WLL must be permanently marked on all blocks and the unique identifying number.

Sheaves and cargo blocks should be inspected:

- for corrosion
- for deformation
- for sheave and pin wear
- to ensure the sheave freely turns
- to ensure that the snatch block retaining pins correctly retains the gate assembly.



Figure 17: Examples of sheaves and cargo blocks

* Refer to appendix 5: Reference Documents

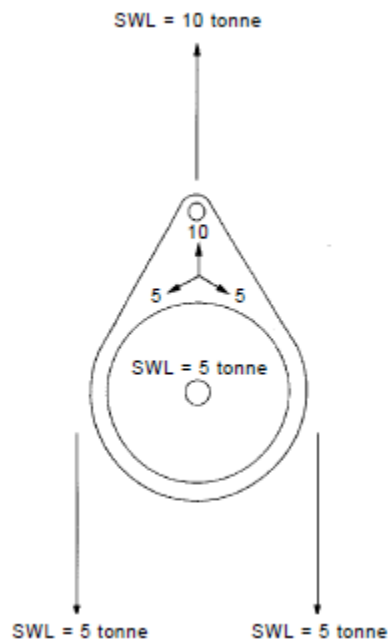

Figure 18: Calculation for single sheave block (note: SWL should read as WLL)

5.6 Lifting beams, spreaders and frames

Lifting beams, spreaders and frames shall be designed to one of the following:

- BS 2573 part 1: *Rules for the design of cranes*
- AS 4991: *Lifting devices*.

Where the design is to BS 2573 part 1:

- welding to AS/NZS 1554.1* and AS/NZS 1554.5* is an acceptable alternative.
- Structural steels as listed in AS/NZS 1554.1 are acceptable alternatives.

Load testing shall be conducted as per AS 4991*.

The design of lifting beams, spreaders and frames shall be certified by a Chartered Professional Engineer or Design Verifier approved by the Ministry of Business, Innovation and Employment as a Crane Design Verifier. The certification documentation shall state:

- the WLL
- design impact factor
- number of lifts it is designed for
- duty rating
- any other item that may be relevant.

Lifting beams, spreaders and frames shall be marked with WLL (tare weight) in figures large enough to be clearly seen.

Documentation for the test load and date need to be clearly seen.

Documentation for the test load and date need to be signed and witnessed by a competent person and then held by the owners of the lifting beam.

* Refer to Appendix 5: Reference Documents

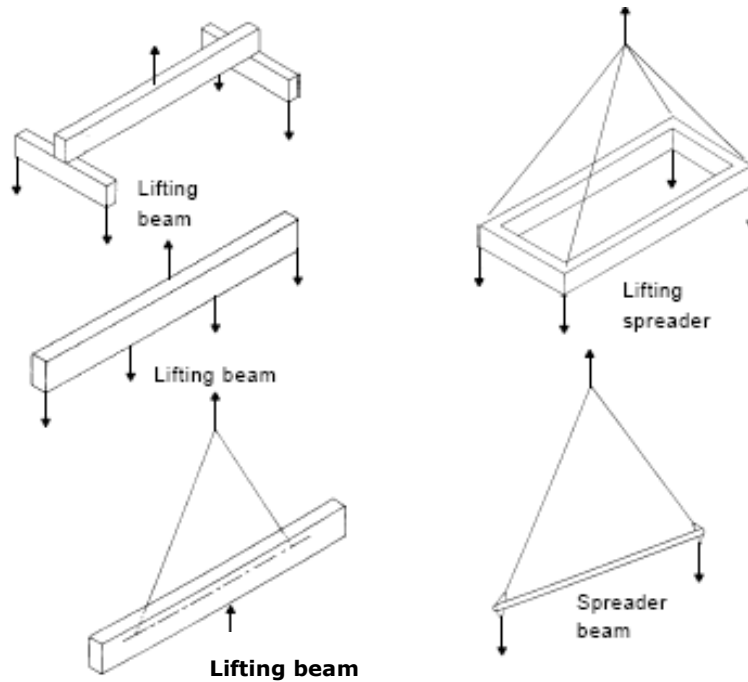

Figure 19: Examples of lifting beams

5.7 Eyebolts for lifting

Refer to relevant Standard BS 4278* or equivalent.

Eyebolts with the pull horizontal to the plate should be shoulder-type only and used in pairs. The load taken by a single eyebolt should be no more than 25% of its marked WLL.

Eyebolts must be tightened so that the shoulder is flush with the item being lifted.

* Refer to Appendix 5: Reference Documents

Table 16: Maximum recommended working loads for collar eyebolts (metric threads) when used in pairs for inclined loading positions

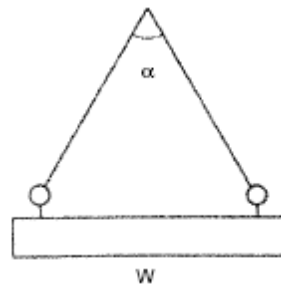

Thread size (Metric)	Axial WLL of single eye bolt	Maximum load W to be listed by a pair of eyebolts when the angle between slings is:		
		$0^\circ < \alpha < 30^\circ$	$30^\circ < \alpha < 60^\circ$	$60^\circ < \alpha < 90^\circ$
mm	tonnes	tonnes	tonnes	tonnes
12	0.40	0.50	0.32	0.20
16	0.80	1.00	0.64	0.40
20	1.60	2.00	1.25	0.80
24	2.50	3.20	2.00	1.25
30	4.00	5.00	3.20	2.00
36	6.30	8.00	5.00	3.20
42	8.00	10.00	6.30	4.00
48	10.00	12.50	8.00	5.00
52	12.50	16.00	10.00	6.30
56	16.00	20.00	12.50	8.00
64	20.00	25.00	16.00	10.00
72	25.00	32.00	20.00	12.50
Reduction Factor		0.63	0.40	0.25

Some eye bolts, whilst complying with British standards, may be marked with lower working load limits than those shown. In these cases, the reduced working load limit for angular loading when used in pairs may be obtained by using the reduction factor given at the foot of Table 16 for each type of eye bolt.

5.8 Chainblocks

Refer to AS 1418.2* or equivalent. Chainblocks must be supplied with relevant test certificates and used in accordance with the manufacturers' recommendations.

All components must have a regular inspection.

* Refer to Appendix 5: Reference Documents

5.9 Lever block

Refer to AS 1418.2* or equivalent. They shall be supplied with relevant test certificates and used in accordance with the manufacturers' recommendations.

All components must have a regular inspection.

5.10 Hooks

Refer to BS EN 1677-5* or equivalent.

Safety catches are to be fitted to hooks unless fitting and removal of the load cannot be physically achieved with a catch fitted, for example: using a molten metal pouring ladle in a steel works.

Hook wear in the lifting area is to be no more than 10% of the hook diameter at that position. The hook/opening throat is to open no more than 5% of the opening.

Hook blocks with cheek/side plates attached are to be checked daily and before each lift to ensure their fixing/welding is secure.

5.11 Other general gear

Tirfor-type winches must be used in accordance with the manufacturers' specifications using the correct rope size and construction.

Lifting components cast in concrete shall have a minimum safety factor of 3:1.

Lifting clutches/eyes for use in lifting items shall have a minimum safety factor of 5:1.

Any other lifting equipment must be in accordance with the manufacturer's recommendations.

5.12 Inspection

It is recommended that all lifting tackle shall be examined by a competent person on a regular basis. This should not exceed a 12-month period, depending on frequency, type of use, and environmental conditions. It is also recommended that for heavily used tackle, proof loading should be carried out every year.

Visual inspection prior to and after use is a requirement.

Any proof loading shall be carried out by a competent person in accordance with the relevant standard or the manufacturer's recommendations. Proof loading must be carried out after any repair, replacement or alteration, along with the examination by a competent person.

* Refer to Appendix 5: Reference Documents

5.13 Register

A register should be kept for lifting tackle, but this is not required for flat web, round slings, wire rope slings, or shackles. An example of this register is shown in table 17. The register should show the date of the last recorded examination or test, and any alterations.

Table 17: Example register - thorough examination of all chains, ropes or lifting tackle

Size	Distinguishing number of mark and description sufficient to identify the chain, rope or lifting tackle	Number of certificate of test and examination	Date when chain, rope or tackle was first taken into use	Particulars of each thorough examination of all chains, ropes or lifting tackle			
				Date and by whom carried out			Particulars of any defect found which may affect the same working load, and steps taken to remedy such a defect. (To be initialled and dated)
				Date and name	Date and name	Date and name	

PART 6: RIGGING FOR CRANE WORK

Further information is available in the LEENZ Code of Practice*.

6.1 General safety requirements

Load-lifting rigging is a hazardous activity. Only trained and experienced personnel should be permitted to undertake rigging activities.

Employees undertaking training in rigging work may conduct load-lifting rigging activities provided that they are directly supervised by a person trained and experienced in rigging practice until they are deemed to be competent.

The following general safety requirements should be followed:

- Keep inexperienced personnel clear of loads swinging overhead, bights of slack rope, lead and snatch blocks, anchorages, or other possible danger points.
- Be sure of the weight to be handled, where it is to be placed, and the capabilities of the gear to handle it.
- Decide the method of slinging and check that suitable slings are on hand.
- Check that the swing area is clear of power lines or other obstructions.
- Prepare or select anchorage points if these are required for tie-backs.
- Once preparations for a lift are complete, proceed with the lift without stopping.
- Lifting equipment should be attached to the load by a competent person, and the immediate areas cleared in preparation for the lift.
- Visual and audible alarms are recommended to warn people to clear the area prior to the start of the lift.
- Exclusion zones shall cover the area directly underneath the operating and lifting area of the crane or lifting appliance.
- Standard signals should be given by one designated person only. "Stop" commands can be given by anyone, and should be obeyed instantly.
- Ropes spooling onto winches should be guided by a piece of wood or similar, not by the hands. Hands should be kept clear of moving ropes, especially near blocks, and kept clear of sling eyes as the load is lifted. Keep fingers out from under loads, especially steelwork.
- Under no circumstances should anyone pass or stand underneath a suspended load.
- Everyone should be outside the lift or drop zone when slewing.

6.2 Evaluating the load

The operator should take all practicable steps to establish the weight of any load. An intelligent "guess" is not good enough. A drawing may be available giving the weight, or it may be calculable within reasonable limits of accuracy. In the case of multi-piece loads (for example, a bundle of steel rods), one item may be weighed to calculate the total weight of the load. If it is likely that the load may have to be lifted again, the weight should be clearly marked on it.

* Refer to Appendix 5: Reference Documents

6.3 Load estimation – weight and centre of gravity

The importance of knowing, with reasonable accuracy, the weight of a load to be lifted and the position of its centre of gravity, is stressed throughout this Code. The following gives guidance as to the various ways of obtaining this information.

6.3.1 Weight

- Look to see if the weight is marked on the load. If it is, check to ensure that it is the weight of all parts of the load; (a machine tool, for example, may not include the driver motor).
- Check the weight stated on any documentation.
- Look at the drawing of the load. If the weight is marked, check as in (1) above to ensure it includes all parts of the load.
- If the load is still on a trailer or truck, weigh it there.
- Estimate the weight of the load by using tables of weights. In this respect, BS4-1 gives the weight of rolled steel sections. Table 18 of this Code gives approximate weights for other materials. Check with the supplier for accurate figures.
- A test lift by the crane to check the load on the crane's load indicator could also be carried out.

Table 18: Example of material weights

Material	Weight in kg per cubic metre
Aluminium	2700
Brass	8500
Brick	2100
Coal	900
Copper	8800
Concrete	2400
Iron-steel	7700
Lead	11200
Oil	800
Paper	1120
Water	1000
Wood	800

Imperial/Metric Conversion

1 ton = 2240lb = 1016kg

1 tonne = 2204.6lb = 1000 kg

US 1 ton = 2000lb = 909kg

Notes

- In some cases, these figures are average only and the actual weight may vary according to factors such as composition/water content.
- All figures have been rounded for convenience of use.

- When dealing with a hollow body, check whether it contains anything and whether any such contents are liable to move.

6.3.2 Centres of gravity

The centre of gravity (CoG) is a point which, if the load could be suspended from it, the load would be in perfect balance.

The crane hook needs to be directly over the centre of gravity for the load to be stable.

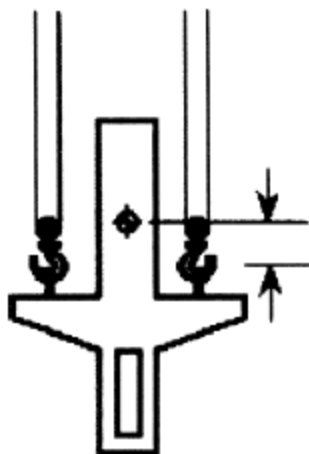

The load is **not** stable. The hooks are under the centre of gravity, and the centre of gravity is above the hooks.

This load is top-heavy, and could overturn while being craned.

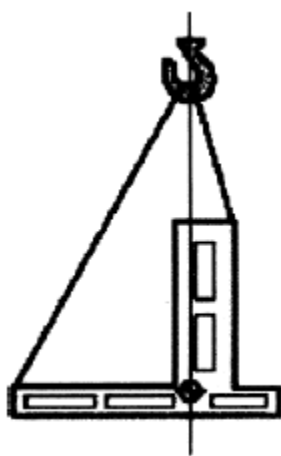

This load is stable. The hook is right over the load's centre of gravity.

Figure 20: Examples of the centre of gravity of loads

Lifting a load with the centre of gravity offset will cause the load to shift until a balance is restored.

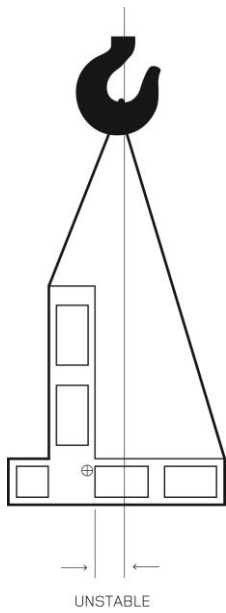

If you start like this...

The hook is **not** over the centre of gravity.

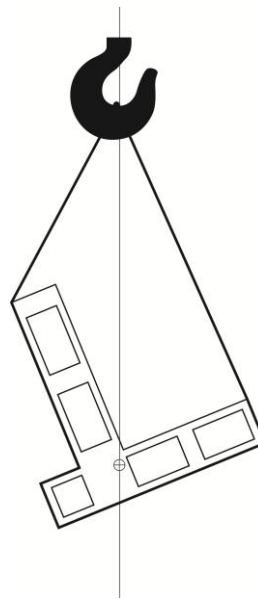

...you will end up like this.

The load will shift until the centre of gravity is under the hook.

This will make landing the load very difficult, and could cause major problems for crane operation.

Figure 21: Example of a load being lifted where the hook is not over the centre of gravity

6.4 Figure 22: Volumes of common shapes

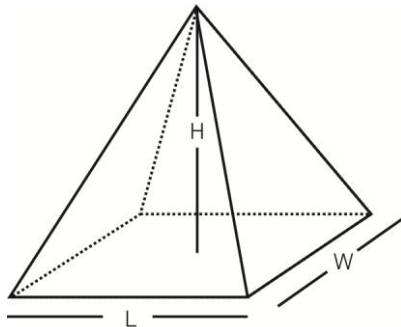

$$\text{Pyramid} = \frac{1}{4} \times L \times W \times H$$

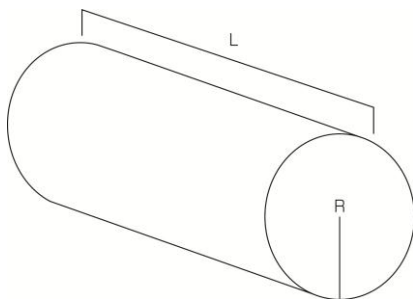

$$\text{Solid cylinder} = \pi r^2 \times L$$

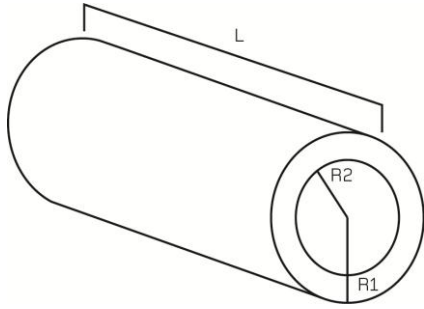

$$\text{Thick walled pipe} = \Pi(r_1^2 - r_2^2) \times L$$

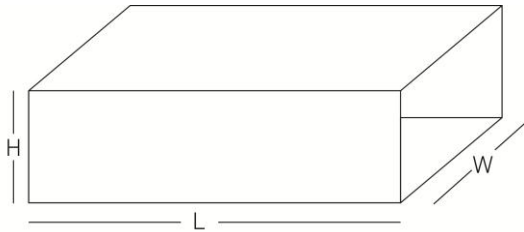

$$\text{Rectangular solid} = L \times W \times H$$

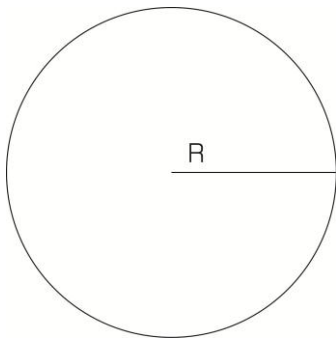

$$\text{Sphere} = 4 \Pi \times R^3$$

6.5 Load security – balance and stability

Before lifting or any moving of the load it is essential to ensure that, when clear of the ground, the load will adopt the intended attitude and remain securely attached to the lifting appliance without overloading any of the lifting gear. This means that the load must be both balanced and stable.

6.5.1 Balance

In the majority of lifts it will be intended that the load will remain level when clear of the ground. To achieve this it is first necessary to position the hook of the lifting appliance vertically above the centre of gravity of the load.

The legs of the sling(s) should be distributed as evenly as is practicable according to the lifting points available. The angle which the individual leg makes with the vertical, affects the proportion of the load which will be imposed upon it and all legs should therefore be, so far as is practicable, at a similar angle to provide equal loading. If the load tilts on lifting, the load in the sling legs will become unequal. This effect is especially significant at small included angles between sling legs.

With rigid loads when three or more legs are employed, consideration should be given to how many of the legs will bear the weight as it may be found that only two or three will

take the majority with the remaining legs providing a relatively small 'balancing force' only. If this is the case, larger capacity tackle will be required.

6.5.2 Stability

In this context, stability means 'resistance to toppling'. An object with a narrow base and a high centre of gravity will need less force to topple it than one with a wide base and a low centre of gravity.

As the height of the centre of gravity increases relative to the width of the base, a point will be reached where the object will fall over unless it is supported by external means. At this point the object is regarded as being unstable and the greater the support required the more unstable it is.

A similar situation exists with a suspended load. Forces which try to topple the load will inevitably be present (for example, wind, acceleration, braking). It is essential, therefore, when slinging a load, to ensure that it is sufficiently stable to resist these toppling forces.

A load will be inherently stable if the lifting tackle is attached ABOVE the centre of gravity and properly positioned around it.

6.6 Structures

In this context, 'structure' refers to any support or anchorage for lifting equipment.

Frequently, such structures are primarily designed for other purposes, for example, a building from which a runway is suspended. It is important to ensure that they are adequate for the purposes of lifting but, owing to the other loads which may be imposed, proof load testing alone is not adequate. The following procedure is therefore recommended.

6.6.1 Overhead beams and gantries

The overhead beams and gantries should be designed, tested and certified in accordance with the PECPR Regulations and *Approved Code of Practice for Cranes*.

Where it is intended to 'turn over' the load when in the air or to position it at an inclined attitude, special consideration should be given to the questions of balance and stability to ensure that at all stages of the operation the load remains balanced, stable and securely attached without overloading any item of lifting equipment.

On occasions, particularly when using a single leg sling, it may be necessary to lift a load such as a pipe or drum with the sling positioned a short distance away from the centre of gravity. The load, when lifted, will then take up a tilted position but will be inherently stable.

6.7 Packing

The need for adequate packing between sling and load is emphasised throughout this code.

The objects of packing are:

- to provide an adequate radius around which a sling may pass without unacceptable loss of load carrying capacity
- to assist the sling in gripping the load
- to prevent damage to the load itself.

It is important to realise that when a sling is bent around a corner its strength will be considerably reduced. Whilst a small radius will prevent the cutting action of a sharp edge, IT WILL NOT PREVENT THE LOSS OF STRENGTH DUE TO INCORRECT LOADING OF THE SLING.

For example, a chain sling passing around a corner may have one or more links loaded in bending, which could result in premature failure of the chain (see figure 23).

Wire rope	Chain		Webbing
			
<p>Minimum radius should be four times and rope diameter.</p>	<p>Chain diameter mm</p> <p>7</p> <p>10</p> <p>13</p> <p>16</p> <p>19</p> <p>23</p> <p>26</p> <p>32</p>	<p>Min radius mm</p> <p>30</p> <p>43</p> <p>50</p> <p>69</p> <p>80</p> <p>96</p> <p>110</p> <p>136</p>	<p>Minimum radius should be four times diameter.</p>

Figure 23: Minimum recommended corner radius for lifting

In the case of a wire rope sling, too small a radius would result in a permanent kink and some of the individual wires being overloaded. Although in both of these examples

failure may not occur immediately, permanent damage will have been done which may subsequently result in failure.

Various materials are suitable for packing. Whatever is used must be capable of taking the crushing forces which will be imposed upon it, and it should be positioned to make best use of its strength.

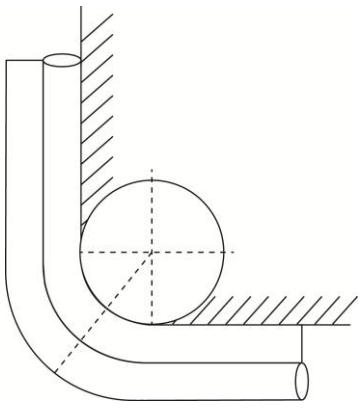
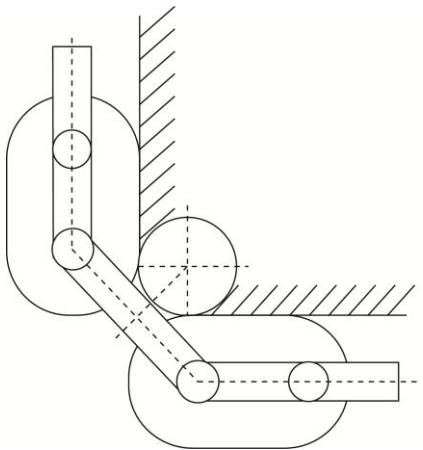
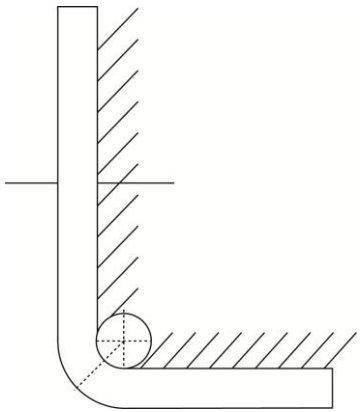
Where a particular load is lifted regularly, purpose designed reusable packing may be found economical, but for general purposes the operative should have available a good selection of materials according to the nature of the work (for example, timber blocks, rubber, sections of old vehicle tyres, conveyor belts).

When positioning packing it is essential to ensure that it will stay in place throughout the lift and any moving of the load, as packing which falls or flies out will be a hazard in itself as well as imposing shock loads upon the lifting equipment. It may, therefore, be necessary to provide some independent means of securing the packing in place.

The amount of packing required varies according to the particular job and in a code of this type it is not possible to cater for every situation. The illustrations in figure 24 provide some examples of good practice.

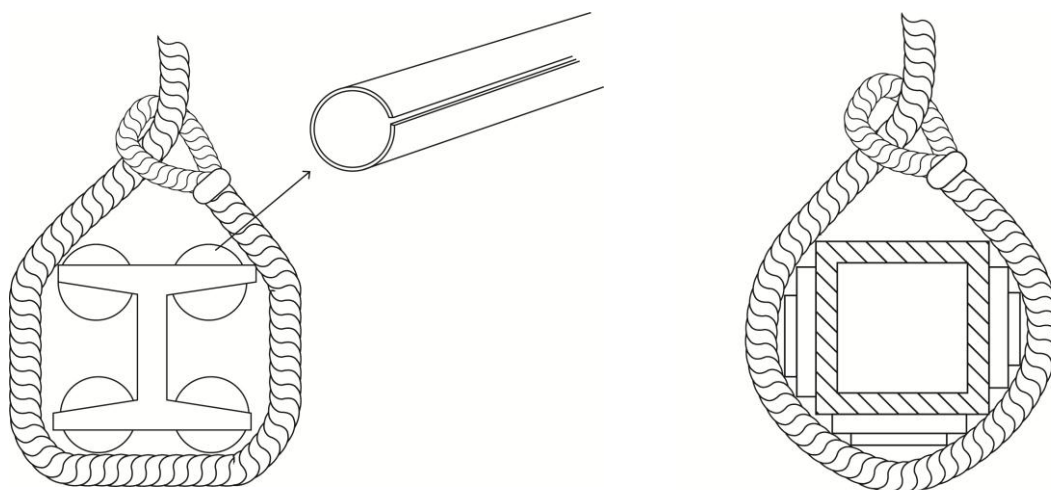

Figure 24: Good standard with adequate radius and no kinking

6.8 Slings

6.8.1 Marking

The following information should be permanently and legibly marked with:

- an identification mark
- the WLL at given angles
- any other information called for by the standard being worked to.

When a multi-leg sling is used with the sling legs at an angle, the load in the individual sling legs will increase as the angle between the legs becomes greater. This is illustrated in Figure 25 for two-leg slings.

Using the angle load factors to determine the load on each leg:

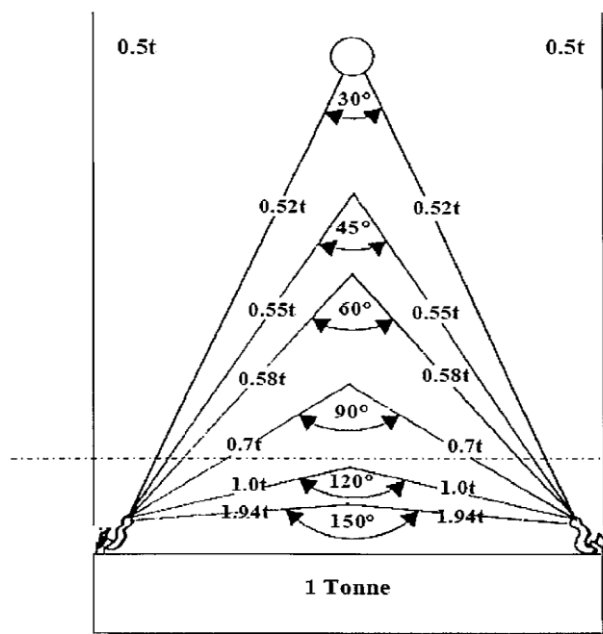

$$W \times F = L$$

W = the weight of the load in tonnes

F = included angle factor on each leg

L = the load on each leg.

Example:

For a 12-tonne load and sling angle of 60°:

The load on each leg is $12 \times 0.55 = 6.6$ tonnes per leg.

Figure 25: Calculations for two-leg slings

Angles greater than 120° are not accepted. The area below the dashed line shows excessive load in sling legs at extreme angles.

Thus, if a sling is to be used safely, allowance must be made for this included angle. This is achieved by rating the sling in one of two ways. This matter is discussed in some detail in BS 6166*, which specifies the method and factors to be used in calculating the WLL.

The trigonometric method is one which has been traditionally used and it allows the working load limit or decrease according to the angle between the sling legs.

The uniform load method simplifies matters by removing the need for tables and reducing the need for the operator to estimate angles.

Both of these methods do, however, assume that certain conditions of use are imposed to ensure that no part of the sling can become overloaded. It is important to understand that although the weight to be lifted may be within the maximum lifting capacity of the sling, lifting in the wrong way can place an excess of load onto one part of the sling. The following diagrams show chain slings but the principles also apply to wire ropes, webbing slings and other slings.

* Refer to Appendix 5: Reference Documents

6.8.2 Recommended methods of slinging under normal conditions

(Where possible, hook from the inside)

1. Straight lift	2. Choke hitch
 <p>WLL: the WLL will be a single-leg.</p> <p>Comments: A suitable method of lifting an effectively-balanced load from a single lifting point.</p>	 <p>WLL: The WLL must be reduced by 20% in this application.</p> <p>Comments: This method forms a loop which tightens as the load is lifted. DO NOT attempt to force the bight into closer contact with the load. Allow the chain to assume its natural angle. Single-leg slings in choke hitch are not suitable for lifting long loads which might tilt or for any load which is not effectively balanced in the single loop.</p>

Figure 26: Single-leg slings

Caution:

- Refer to minimum radius.
- Refer to included angle chart.

3. Single leg in basket hitch (back hooked into top link)

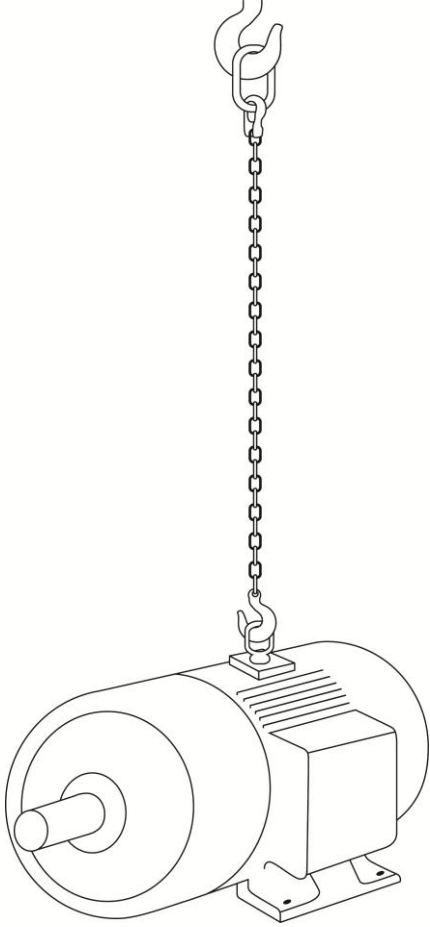
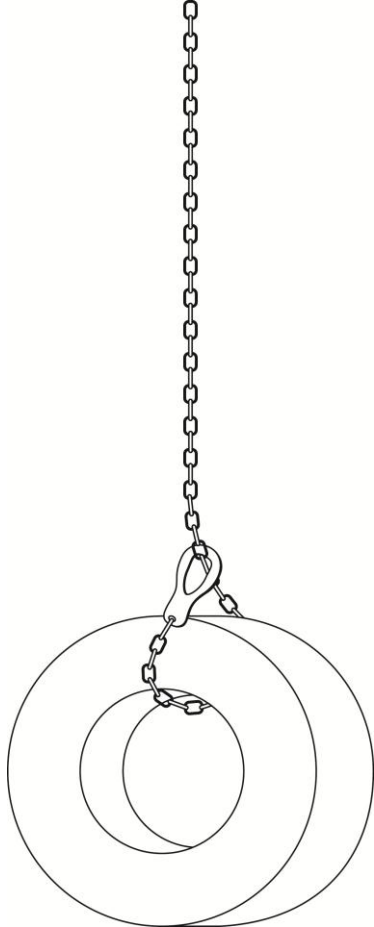
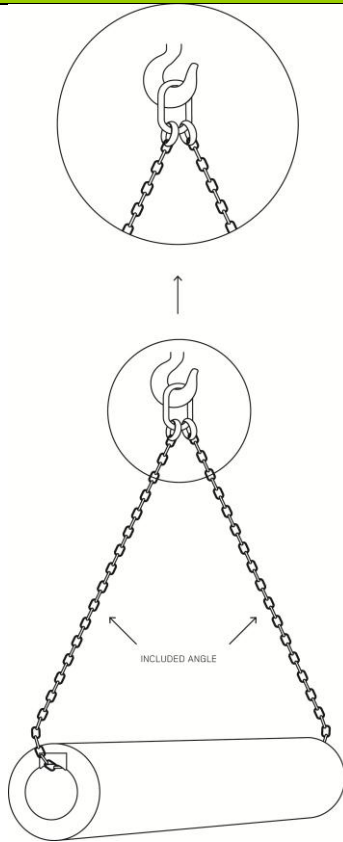

WLL: The WLL will be rated by that of a single-leg sling reduced by the included angle. Refer to relevant charts.

Comments: A single-leg sling back hooked to form a basket hitch assumes the appearance of a two-leg sling but it should never be rated as such. It should be noted that the master link is only designed for single leg loading and therefore the single leg WLL should never be exceeded.

4. Reeveable collar sling in basket hitch

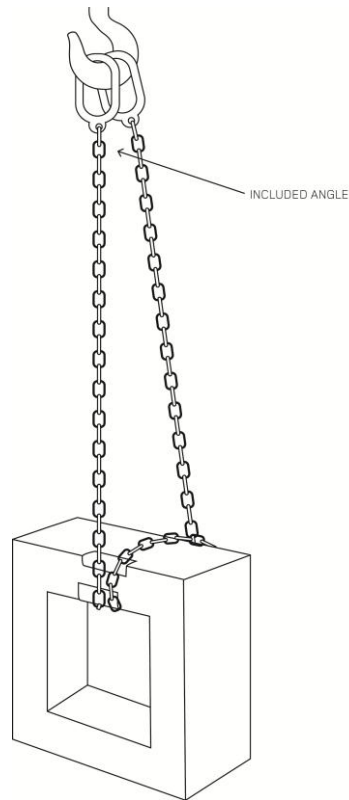

WLL: The WLL will be that for a two-leg sling reduced by the included angle. Refer to relevant charts.

Figure 27: Single-leg slings in basket hitch

Caution:

- Refer to minimum radius.
- Refer to included angle chart.

5. Single adjustable basket sling

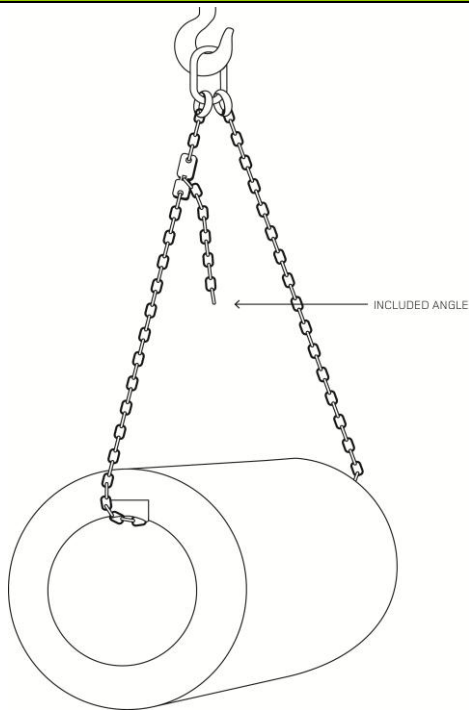

WLL: The WLL will be that for a two-leg sling reduced by the included angle.

Comments: A suitable master link must be fitted for two-leg rating.

6. Two single legs in straight lift

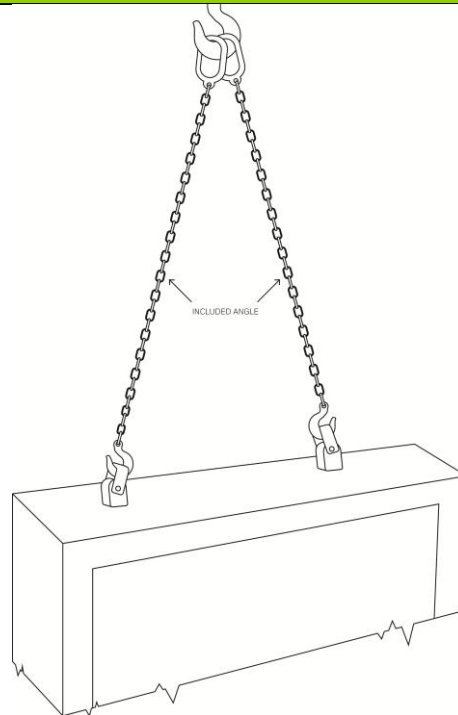

WLL: Rate as a two-leg sling. The WLL will therefore depend upon the included angle.

Caution: (example 5)

- Refer to minimum radius.
- Refer to included angle chart.

Comments: (example 6)

Two single-leg slings should not be used together to form a pair unless:

- they are the same type, grade, size and length
- they are both marked with the same WLL
- the crane hook is large enough to comfortably accept both upper terminal fittings of the slings.

Caution: (example 6)

- Refer to minimum radius.
- Refer to included angle chart.

7. Two single legs in choke hitch	8. Two single legs in basket hitch
 <p>* WLL calculated as per No. 6 then reduced by 20% because it is choked. For loose items, double wrap is recommended.</p> <p>WLL: The WLL will be reduced by 20% in this application. Choke hitch with included angle greater than 60o is not recommended as sideways shifting may occur.</p>	 <p>WLL: Rate as a two-leg sling. The WLL should be no more than that applicable to an equivalent two-leg sling.</p>

Figure 28: Two single-leg slings used together

Comments:

Two single-leg slings should not be used together to form a pair unless:

- they are the same type, grade, size and length
- they are both marked with the same WLL
- the crane hook is large enough to comfortably accept both upper terminal fittings of the slings.

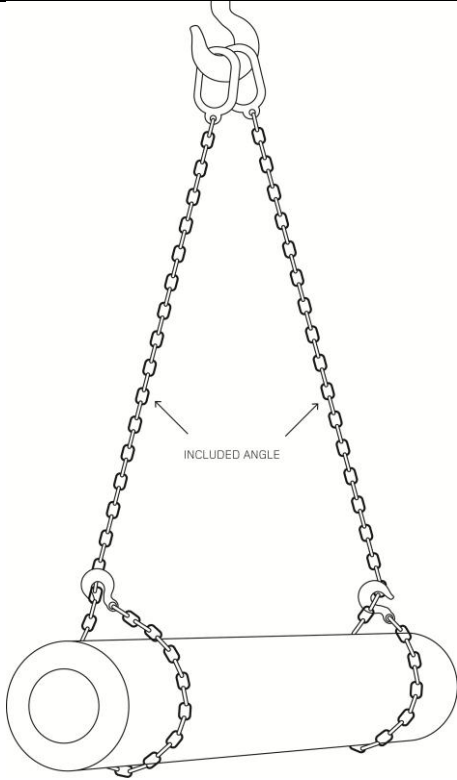
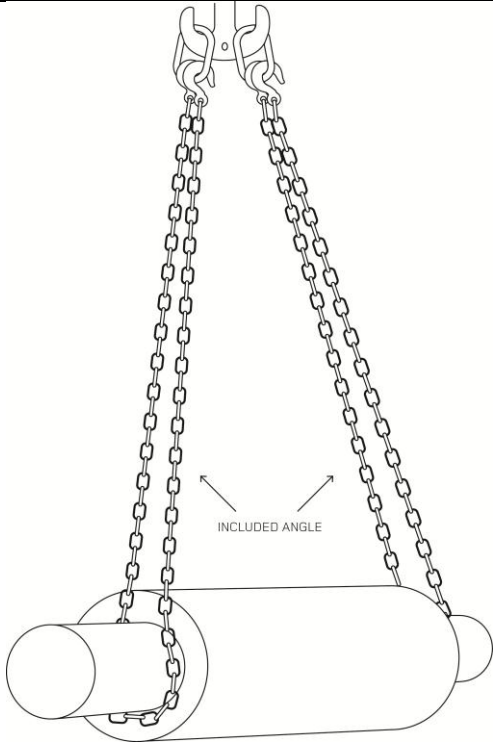
Caution:

- Refer to minimum radius.
- Refer to included angle chart.

9. Straight lift

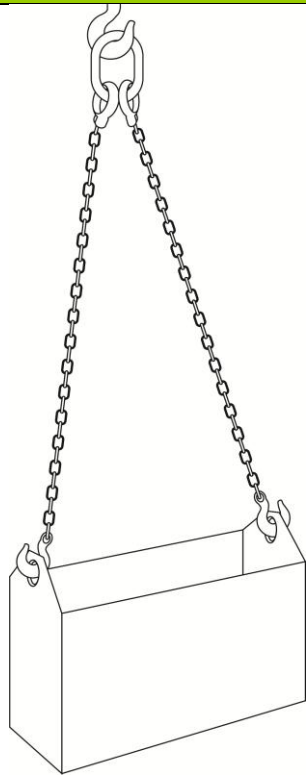

WLL: Rate as per load chart tables depending on included angle.

10. Choke hitch

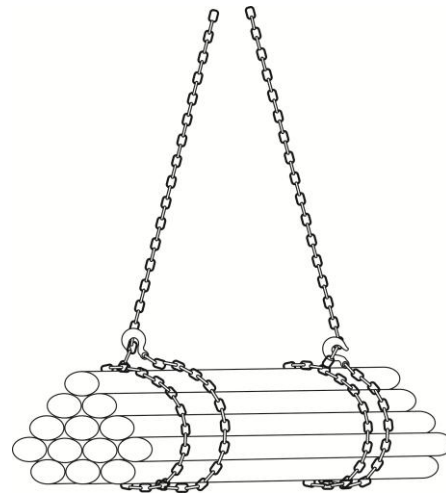

Note: For loose items or a better grip, double wrap is recommended.

WLL: The WLL is calculated as per No. 1 then reduced by 20%.

Figure 29: Two-leg slings

Caution:

- Refer to minimum radius.
- Refer to included angle chart.
- With double wrap, ensure the sling does not cross under the load.

Note: Always hook from the inside.

11. Basket hitch	12 Straight lift
	
<p>WLL: Rate as per load charts depending on included angle.</p> <p>Comments: The included angle should be measured between diagonally opposite legs. Rate as indicated above only in cases where the load appears to be reasonably equally distributed between all four legs. If two legs are obviously supporting most of the load, rate as a two-leg sling. If three legs are obviously supporting most of the load, rate as a three-leg sling.</p>	<p>WLL: Rate as per load chart table depending on included angle. Be aware of minimum pin diameter for basket hitch.</p> <p>In example 12 the sling assumes the appearance of a four-leg sling but it should be noted that the master link will be designed for two-leg loads only and the sling should therefore be rated as a two-leg sling.</p>

Figure 30: Basket hitch and four-leg sling examples

Caution:

- Refer to minimum radius.
- Refer to included angle chart.

6.8.3 Criteria for sling selection

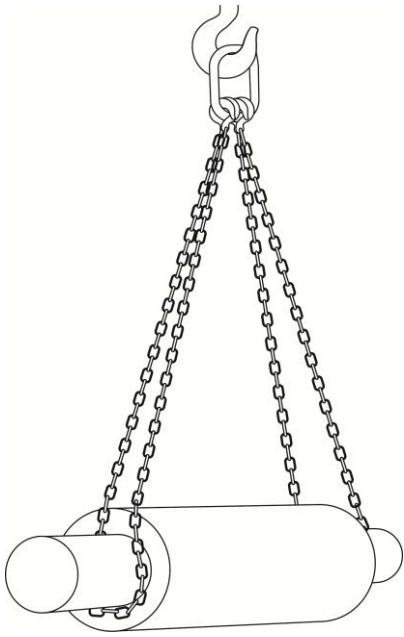
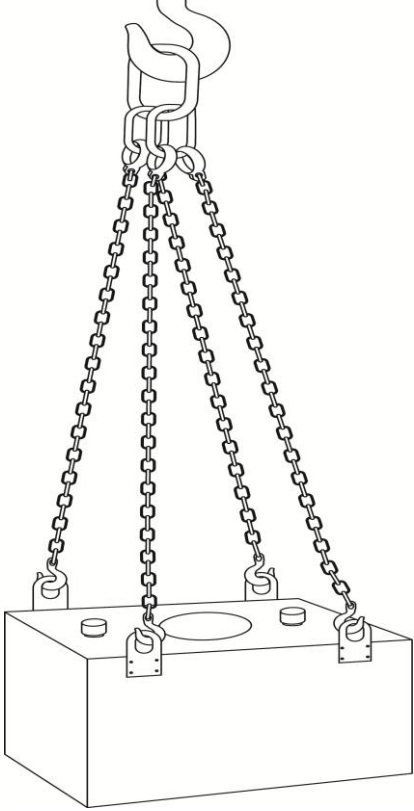
The nature of the load

With regard to the nature of the load, the aspects to be considered include the temperature of the load, the presence of sharp corners and polished surfaces. Rope or webbing is unlikely to be suitable for a hot load. If the load has sharp corners, chain might be more durable but, even so, edge protection will be necessary. If the load is polished or delicate in some other way, then man-made fibre webbing, a round sling or fibre rope is likely to be best.

The environment in which the sling operates

If a corrosive environment is involved, for example in a plating shop, this is a complex problem and specialist advice should always be sought. It should also be remembered that worksites such as laundries, swimming pools, pumping stations and sewage works can also give rise to corrosive conditions.

If outdoor use is involved, natural fibre ropes are liable to rot and mildew, and wire ropes are liable to corrode. Situations such as marine conditions, atmospheric pollution, construction sites involving rock and mud will all aggravate outdoor environmental problems.

Handling of the sling

Weight, flexibility, hand contact and length adjustment are some of the factors likely to be important when handling the sling. Fibre slings are lightest for a given lifting capacity and may be most suitable where frequent lifting and carrying of the sling is necessary. It should be remembered that chain and round slings flex easily, but cannot readily be pushed through a narrow gap whereas wire rope may. The effect of hand contact may be a consideration when handling the sling. Wire rope or chain is hard and cold to the touch whereas fibre is relatively larger in diameter (useful if pulling is involved) and warmer to handle. Wire rope is susceptible to broken wires.

Durability

Abrasion, storage and other factors will all influence durability. If abrasion is likely, then chain is most durable. Fibre slings are most subject to abrasion damage. If storing lifting tackle for long periods between use, a chain sling might be more suitable, as other types are prone to various forms of deterioration, unless stored under ideal conditions.

Stretch (extension)

Synthetic ropes, flat web and round slings may be less suitable if stretch is likely to be a problem, for example, for precise positioning.

6.8.3 Use of slings

The basic objective of good slinging practice must be to ensure that the load is safe and is as secure when slung in the air as it was on the ground.

Basic principles

- The sling and its method of use should be suitable for the load.
- The method of attachment of the sling to the load and the sling to the lifting appliance should be secure.

- No part of the sling should be overloaded either by the weight of the load or by the method of slinging.
- The slinging method should ensure that the load is secure and that the load will not fall from the sling.
- The load should be balanced and stable and should not violently change its attitude when lifted.
- The load must not be damaged by, or cause damage to, the sling.

If any of the basic principles are not met, then it is possible that a large portion of the load will be imposed on only one, or at best, two legs of the sling. In such circumstances, it should be assumed that the entire load is being carried by one leg, so the sling should be de-rated accordingly as described in the example below by assuming that only one leg is in use.

If a multi-leg sling is used with less than its actual number of legs attached to the load, then obviously the working load limit of the sling must be reduced. The amount by which it should be reduced can be calculated exactly but it is rather complex as a number of factors need to be taken into account, including the method of rating. An easy way of ensuring that the sling is never overloaded is to reduce the WLL from that marked on the sling according to the number of legs in use.

Examples:

1. A four-leg sling with only two legs in use:

$$\text{reduced WLL} = \frac{2}{4}$$

or $\frac{1}{2}$ of marked WLL

2. A three-leg sling with only two legs in use:

$$\text{reduced WLL} = \frac{2}{3} \text{ of marked WLL.}$$

Note: The above only applies to the four- or three-legged rating, NOT the single-leg rating.

This inevitably means that, in some cases, the sling will be underutilised. If maximum utilisation is required, then reference should be made to a person who understands the factors involved and can therefore perform the necessary calculations.

6.8.4 Some essential precautions

Before lifting the load

The weight of the load shall be ascertained before lifting. The lifting method selected should be suitable for the load. The sling should be strong enough for the load, both in terms of its working load limit and its actual condition. The sling shall be carefully inspected for obvious defects before use.

The load should be secure, stable and balanced when lifted. This requires an assessment of the position of the load's centre of gravity to ensure that the lifting point is approximately over it. Failure to do this assessment is likely to cause the load to swing wildly on being lifted, or even to fall out of the sling.

Any loose parts of the load should be adequately secured.

When fitting the sling to the load

The sling shall be firmly secured to the load, for example by means of hooks on to purpose-designed lifting points eyebolts, or by a suitable method of slinging. The sling must not be twisted, knotted or kinked in any way, nor should the lifting points be overloaded by the slinging method. The rated included angle of 120° shall not be exceeded, and the angle at any choke shall not exceed 120° or the angle at any basket should not exceed 120°.

When using three- or four-leg slings with out-of-balance loads or with unequally spaced legs, two legs may support the majority of the weight while the other leg or legs merely act as a balancer. If the lifting points on the load are not in the same horizontal plane, the load - if it is flexible enough - will distort to accommodate the equal leg lengths of the sling. Alternatively, if the load is rigid, two legs will be likely to support the majority of the weight and may be overloaded while the remainder provide the balancing load.

It is essential that any sharp corners on the load are adequately packed by dunnage, for example, to prevent damage to the sling.

6.8.5 Working load limits (WLLs)

The working load limit is the maximum mass which may be raised, lowered or suspended under specific service conditions. The onus is on the operator to obtain a competent person's assessment of a WLL in the light of that person's knowledge of the particular conditions of service.

There are basically two methods of arriving at WLLs for chain slings although variations on these two methods are possible.

The trigonometric method

This is the traditional method used in New Zealand. Its advantage is its familiarity. Most slingers will be acquainted with the load charts, which are an essential part of this method, and this is the rating system that is recommended in this code.

The theory behind this method is mathematical. The WLL of a multi-leg sling is calculated from the force induced into the legs of the sling by virtue of the mass of the load and the angle of the legs to the vertical.

The uniform load method

It has been proposed that a simpler method of rating slings than that outlined above would be preferable. It is argued that slingers sometimes do not have the time or inclination to consult tables, although this argument is largely answered by the availability of pocket load tables. The trigonometric method requires the slinger to be practised in estimating included angles, whilst the uniform load method only requires a

slinger to be able to recognise two included angles of 90° and the overall limiting angle of 120°. The uniform load method makes greater provision for accommodating unequal loading of the legs of a multi-sling in that in most cases (though not all) this method produces a lower WLL than the trigonometric method.

The uniform load method proposes a fixed relationship between the WLLs of single-leg and multi-leg slings according to the following table:

Table 19: Relationship between uniform load method and WLL of single- and multi-leg slings

Single-leg	Two-leg Included angle	Two-leg Included angle	Three- and four-leg Included angle	Four-legged Included angle
	0° - 90°	90° - 120°	0° - 90°	90° - 120°
1.0	1.4	1.0	2.1	1.5

A multi-leg sling, therefore, has only one WLL applicable to all included angles up to 90° and the WLL is stamped on the sling itself thus obviating the use of tables. For use at angles greater than 90° and up to 120° a second, lower WLL is allocated and stamped on a 'tab' which is affixed to the sling.

Whichever rating method is used, multi-leg slings MUST NOT be used at an included angle greater than 120°.

6.9 Good slinging practice

The safe and competent use of lifting gear cannot be adequately learned from a code. A good rigger learns their trade only after practical training and lengthy experience. However, this section establishes some sound basic principles and highlights some of the major malpractices which must be avoided.

6.9.1 Tip loading of hooks

All hooks are designed to support the load in the bowl. Users should ensure that the hook of a sling engages freely in the lifting point so that the weight of the load is supported in the bowl of the hook.

Wedging or forcing the hook tip into the lifting point results in the hook being stressed in a manner for which it was not designed. This may easily lead to hook deformation and premature failure.

Safety catches are to be fitted unless fitting and removal of the load cannot be physically achieved with a catch fitted, for example: a molten metal pouring ladle in a steel works.

6.9.2 Knotting and twisting and transverse bending of chain

Chain is designed to support a load in a straight line with the line of force running through the crowns of each link. Chain which is twisted or worse, knotted, cannot develop its full strength and will almost certainly fail prematurely. Users should remove twists from a chain leg before lifting and should NEVER knot a chain. If it is necessary to shorten a chain, a shortening clutch should be used.

Similarly, chain which is bent under tension around a corner is stressed in a manner for which it is not designed. The user should use timber (or other suitable material) packing pieces to reduce the severity of this type of stressing.

Misuse of Shortening Clutches

Clutches can be misused. Ensure that the chain carrying the load always leads out of the bottom of the clutch as illustrated. If the direction is reversed so that the load carrying chain leads out of the top of the clutch this can result in the front portion of the clutch being pulled off and the load being released.

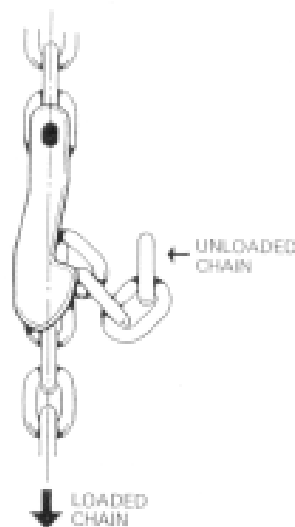

Figure 31: Shortening clutch

Load stability

Good riggers will develop the habit of assessing usual loads and estimating the centre of gravity and then attaching the sling in such a manner that the centre of gravity is below the lifting points, or if this is impossible, well within them. If there is the slightest doubt of the stability of a load, it should be slowly lifted just clear of the ground. If the load tilts, the sling should be re-fixed in a more stable position.

CAUTION: HAMMERING DOWN IS DANGEROUS.

It is sometimes imagined that slings in choke hitch can be made more secure by striking the hook or link or adjacent chain in an attempt to force the bight into closer contact with the load. This dangerous malpractice is often known as 'hammering down'.

The bight should be allowed to assume its natural angle, but should not exceed 120°.

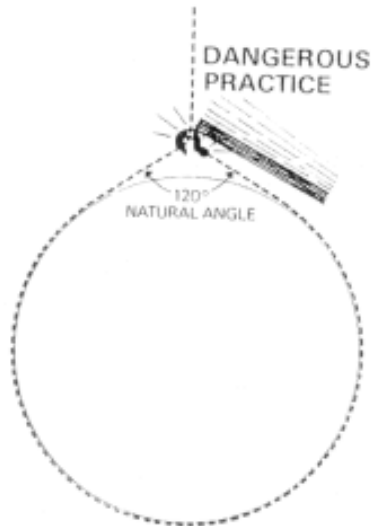

Figure 32: Hammering down is dangerous

6.9.3 Care in the use of alloy chain slings

Alloy chain slings sometimes have to be used in conditions which are potentially dangerous. Whilst such conditions may be avoidable, users should remain keenly aware of the penalties for carelessness and take every possible step to reduce the danger.

The user should make quite certain that potentially dangerous conditions are taken fully into account in choosing a sling of adequate size.

In particular, the user should bear the following in mind:

- high temperature conditions
- acidic conditions
- compression loads
- shock loading
- tag lines
- hand signals
- landing the load
- hooking back unused legs
- sling stowage
- care in the use of flat web and round slings
- care in the use of wire rope slings.

These are further explained in the following paragraphs.

High temperature conditions

The strength of all alloy chain slings is adversely affected at elevated temperatures. If, therefore, slings are used in direct contact with, or in close proximity to high temperature loads, the WLL must be reduced as follows:

Chain Temperature	Reduction in WLL
Up to 200°C	Nil
200°C to 300°C	10%
300°C to 400°C	25%
Over 400°C	Do not use

Table 20: Temperatures and WLL reduction

If it is suspected that a sling has been exposed to temperatures above 400°C, the sling should be referred to a competent person for a decision on its suitability for further use.

Low temperature conditions

Slings are safe at temperatures down to -30°C. But do not use slings below this temperature.

Acidic conditions

Slings are not recommended for use in acidic environments, whether immersed in acid solutions or used in atmospheres in which acid fumes are present. Steel of the type used in slings is vulnerable to hydrogen embrittlement when exposed to acids. Retaining pins being hollow and thin walled are quickly attacked by acids.

Compression loads

High included angles increase compression forces on the load being lifted. Ensure that the load being lifted is capable of withstanding these forces. If in doubt, decrease your sling angle or use alternative methods.

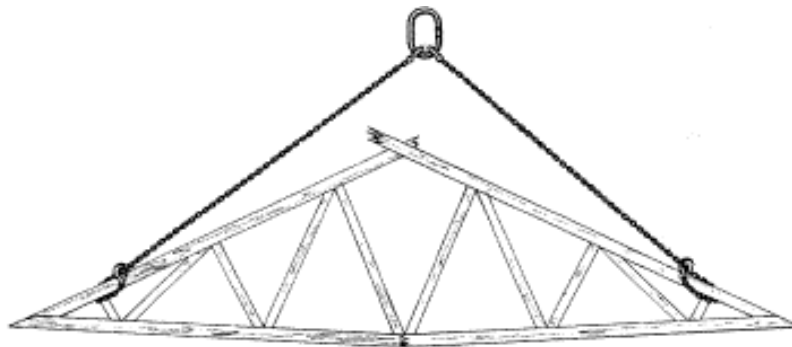

Figure 33: Compression impacting on a roof truss

Shock loading

Shock loads may break your slings even though the weight of the load being lifted is well below the working load limit for that sling. High acceleration forces or shock loads may be caused by the sudden operation of the crane by not taking up slack before starting to lift or by the sudden impact of falling loads.

Tag lines

When lifting long loads, particularly in confined spaces, riggers should attach a rope or 'tag line' to one or both ends of the load so that rotational movement may be controlled.

The load should be travelled at a slow pace and as close to floor level as practicable.

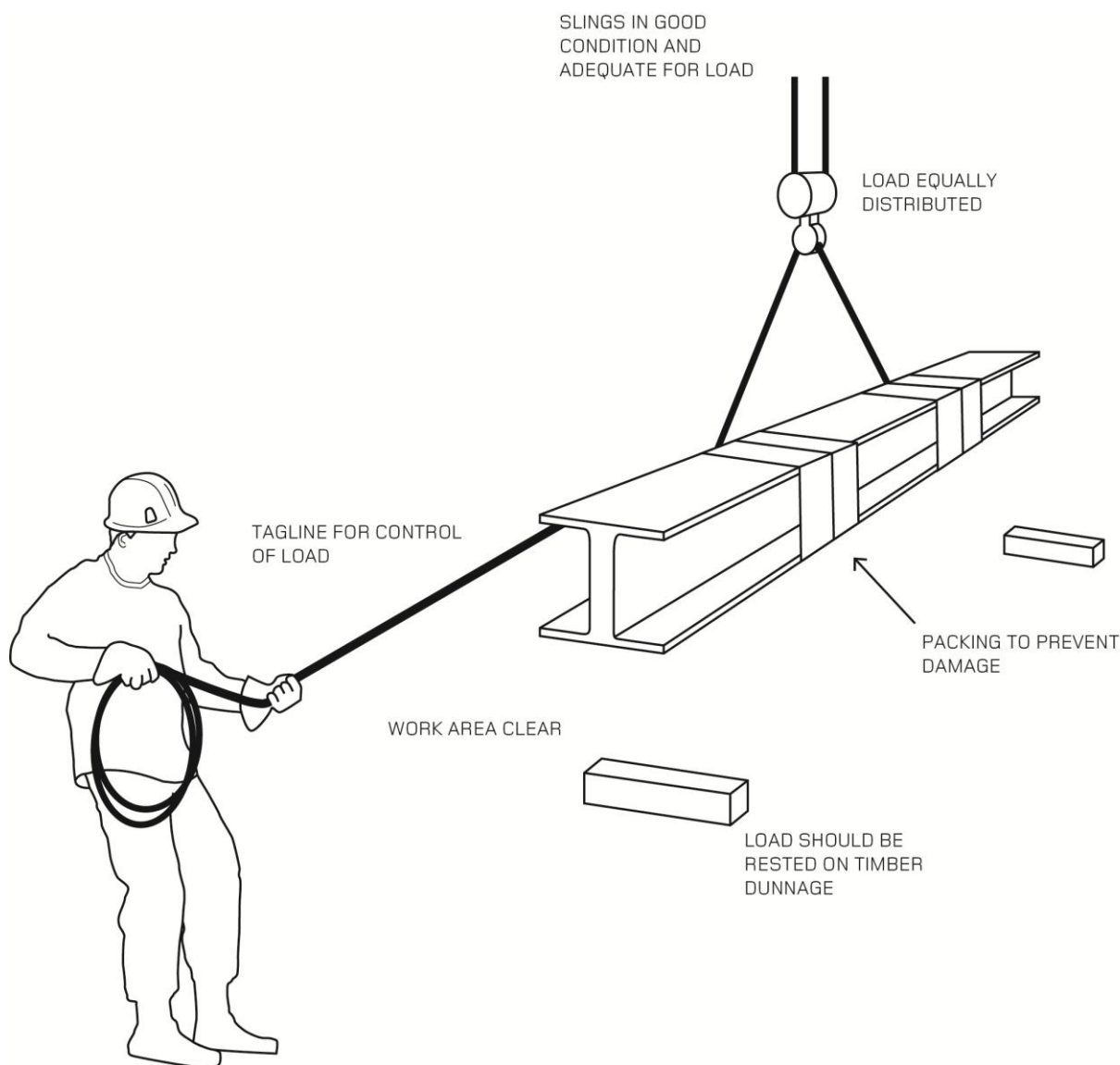

Figure 34: Using tag lines

Hand signals

Riggers and crane operators should use the hand signals shown in the *Approved Code of Practice for Cranes* and the Crane Association of New Zealand (Inc) Safety Manual. The Hand Signals produced in the *Approved Code of Practice for Cranes* is reproduced in Appendix 4.

Before lifting operations commence, there should be an agreement between the crane operator and the riggers that only one rigger is in charge of a lift and only that person will give signals. The crane operator should ignore signals from all other personnel

except the EMERGENCY STOP signal which may be given by anyone present and must always be acted upon.

Landing the load

Before a load is lifted, a place should be prepared where it is to be put down. The nature of the load will determine the type of preparation necessary, but most loads should be lowered onto timber battens. The sling may then be easily withdrawn. The load should never be landed directly on to the chain.

Hooking back unused legs

In the case of multi leg slings with not all legs in use, the unused legs should be hooked back by engaging the hook in the master link or the quadruple master assembly. Similarly, after finishing a lift, if the sling is to remain on the crane hook, all hooks should be hooked back into the master link or the quadruple master assembly.

Sling stowage

When lifting operations are finished, slings should be removed from crane hooks and stowed on a properly designed rack. They should not be left lying on the floor where they may suffer mechanical or corrosion damage or may be lost.

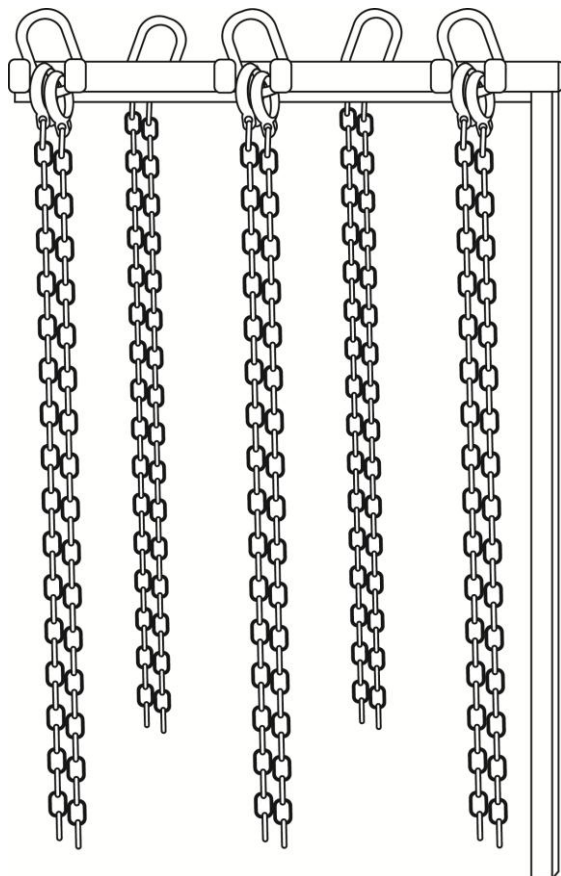

Figure 35: Storing chain slings

Care in the use of flat web and round slings

Flat web and round slings can be easily damaged.

Avoid:

- overloading
- contact with sharp edges
- exposure to heat
- chemical solutions (unless manufacturer's instructions allow)
- grit or abrasive materials (**Caution:** grit can get into and under-wear sleeves).

Never:

- tie knots in slings
- use a sling when the WLL cannot be positively identified (WLL tags or manufacturer's colour/stripe identification).

Always make sure you identify the load rating for the sling.

Note: A nylon sling's load rating is reduced by 15% when wet.

Care in the use of wire rope slings

Avoid:

- overloading slings
- contact with sharp objects
- dragging slings over abrasive surfaces
- distortion of eyes by use of small hooks or shackles
- passing the rope around small diameter turning points (including shackles or hooks)
- using undersized slings
- excessive wear.

Always make sure the load rating for the sling is identified.

6.10 Radio communication

The use of two-way radios for communication in the crane industry has become an essential part of day-to-day lifting operations.

Radios are normally used in one or more of the following situations:

- where the load being lifted is not visible to the crane operator and/or dogman
- where hand signals may not be clearly seen because of:
 - the height of load
 - the height of lift
 - distance
 - obstructions and site conditions
 - weather conditions
 - multiple lift operations.

People using two-way radios for communication should be familiar with the manufacturer's operating instructions.

In the interests of safety the following recognised standard procedures **MUST** be followed when radios are in use:

- Prior to commencement of any task on site the radios to be used **MUST** have an operating safety check to ensure they are performing satisfactorily and the battery is charged. A spare battery should be available.

- A dedicated channel should be used for each lifting operation. Check for other radios in use on the site.

Radio Spectrum Management (Part of the Ministry of Business, Innovation and Employment – Economic Development Group) have allocated specific radio channels for crane control as part of their Radio Licence Engineering Rules. For further details, refer to the *Radio Certification Licence Rules Engineering Rules and Information for Approved Radio Certifiers and Approved Radio Engineers* (refer to Appendix 5).

- Operators should familiarise themselves with any particular worksite procedures regarding the use of radio communication on that site.
- A “constant talk” method should be adopted requiring the radio users to talk in such a manner that the progress of the task is continuously made known to people involved at all times.
- To eliminate any misunderstanding, crane operators should take radio instructions from one competent person only. Special circumstances may require specific arrangements to be put in place when using more than two radios.
- To ensure reliable and prolonged service, all radios MUST be kept fully charged, dry and handled with care.

All crane operations MUST cease immediately if any loss or deterioration of radio communication occurs.

Be aware of interference and signals from other radio users.

6.11 Winches, sheaves and purchases for flexible steel wire rope

6.11.1 Sheaves

Sheaves lead the rope over the head of cranes and hoists and are used in pulley systems to gain a mechanical advantage.

Flare angle and groove depth

The groove depth of a sheave should not be less than 1.5 times the rope diameter. However, if the rope is positively prevented from leaving the groove, the minimum depth of the groove can be equal to the rope diameter.

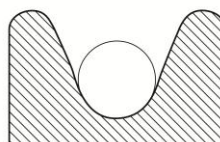

Figure 36: sheave groove with rounded-off flared edges

The sheave groove sides should have a flare angle of a minimum of 42° and a maximum of 52°.

The grooves should be slightly larger than the nominal diameter of the rope. Grooves which are too large will flatten the rope. Grooves which are too small will pinch the rope and the extra friction can cut it to pieces.

Sheaves should have a smooth finish with flared edges which are rounded-off.

Sheave diameters

Caution: Modern cranes and hoists are pieces of complex engineering equipment, and many have specially-constructed luff and hoist ropes. It is essential that the sheaves which are designed for a particular crane or hoist are used for that purpose.

It is also essential that when a rope is replaced, the replacement is the same diameter and of suitable construction. The sheave system should be thoroughly checked to ensure that any damaged or worn grooves likely to ruin the new rope are repaired or replaced.

Table 21: Recommended minimum sheave diameters for maximum rope life - multiple of rope diameter

Rope	Construction	Multiple
6 x 7	6/1	43
6 x 19	12/6/1	26
6 x 19s	9/9/1	32
6 x 24	15/9/F	22
6 x 25	12/6 + 6F/1	26
6 x 31	12/6 and 6/6/1	25
6 x 41	16/8 and 8/8/1	20
18 x 7	6/1	32
34 x 7	6/1 NR	23

Formula: Recommended sheave diameter = rope diameter x multiple.

6.11.2 Reeving

Large capacity cranes have several parts to the main hoist fall, making the main hook very slow.

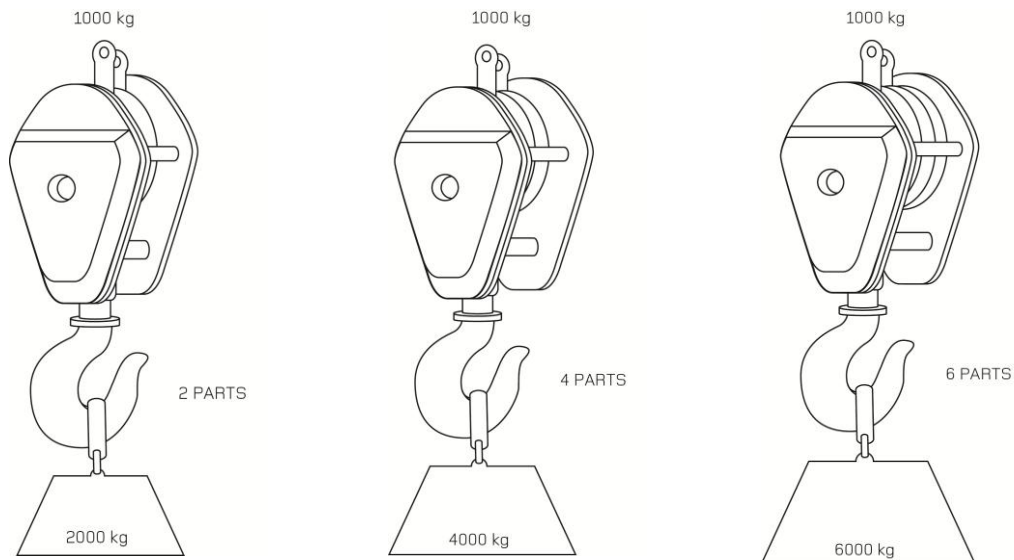

Figure 37: Reducing the number of parts

When reducing the number of parts to give a faster hook, ensure that the falls are not reduced from one side of the boom head sheaves and the main hoist block, otherwise rotational torque can develop on the boom head, exerting side pull on the main hoist block. When reducing parts, the rope must be reeved again to ensure that there are an equal number of parts either side of the boom head and the main hoist block.

The number of parts must be capable of supporting the load to be lifted. A fast hook must still be a safe hook.

Inspection

Sheaves should be inspected regularly. Pay particular attention to the sheave groove and flange. Any cracks or chips on the flange can cut the rope as it lays into the groove.

The groove should be checked for wear which will result in the reduction of the groove diameter and give an uneven bearing surface for the rope.

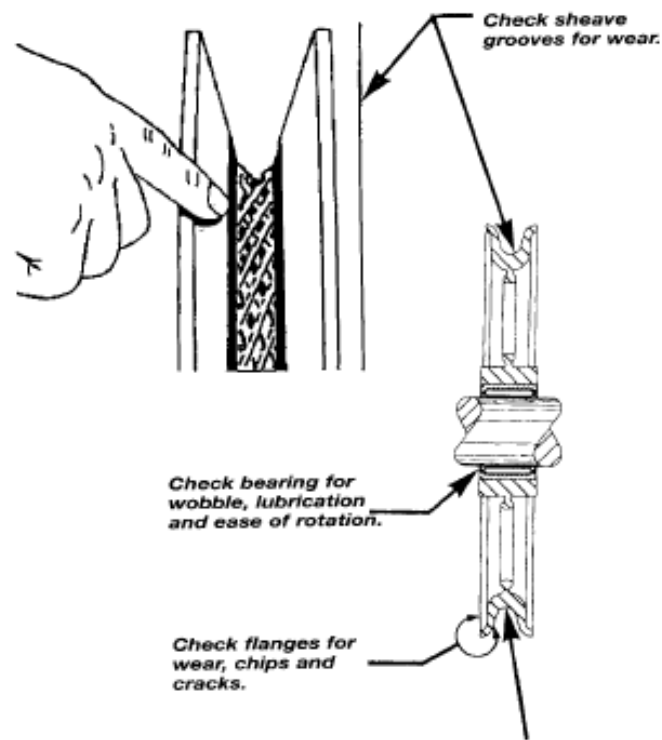

Figure 38: Checking groove for wear

All sheaves should be checked for lubrication. Badly lubricated sheaves cause extra friction in the system and wear on the sheave pin and bearing.

The pin should be prevented from rotating with the sheave. Some sheave pins only have a small cotter pin which fits into a recess on the cheek plate. The cotter pin sometimes shears and allows the pin to turn with the sheave. Rotating pins are dangerous as they turn and cut through the cheek plate.

A 'jockey sheave' is sometimes used as the first diverting sheave to reduce the flare angle.

This sheave fits on an extended pin to allow it to slip from side to side, reducing the flare angle. The jockey sheave pin should be kept well-greased and free from grit and dirt to allow the sheave to slide across the pin.

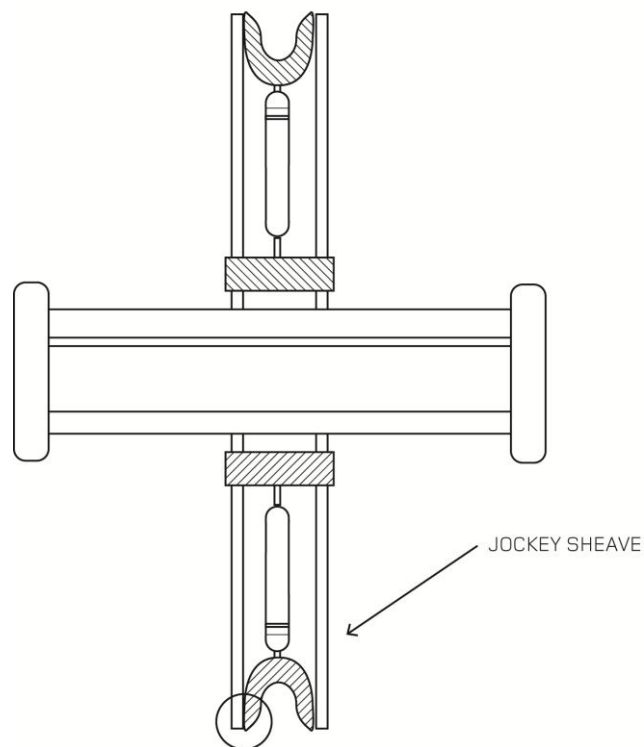
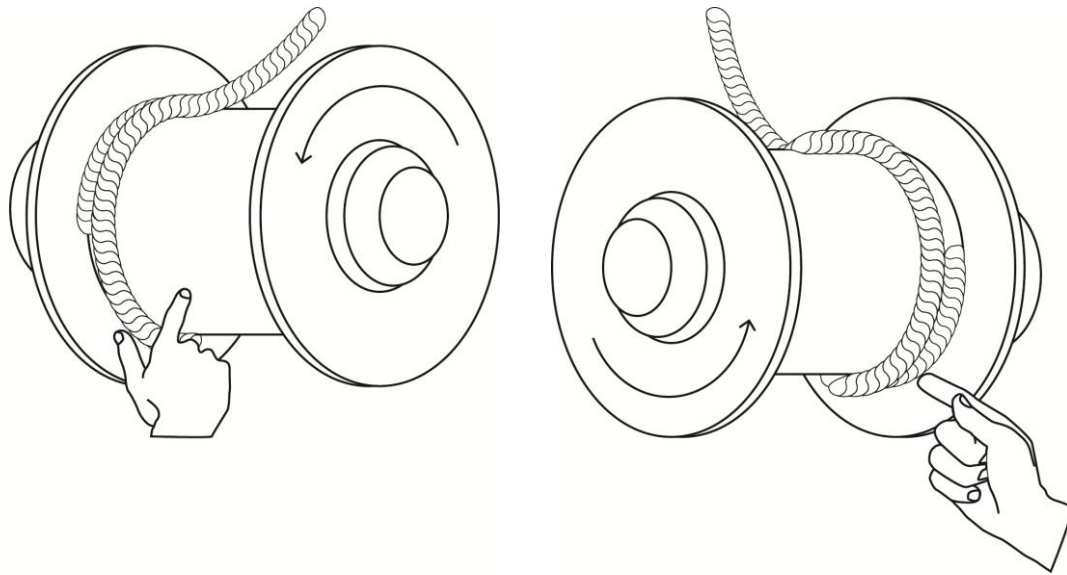

Figure 39: Jockey sheave

6.11.3 Drums

Drums are the pulling mechanisms which rotate, haul in and store surplus wire. The braking mechanism is connected to either the drum or the gearing which is joined to the drive mechanism.

The rope should lay neatly on the drum and not be bunched up. There should be a minimum of three full turns on the drum at all times.



(A) RH LAY ROPE OVERWOUND

(B) RH LAY ROPE UNDERWOUND

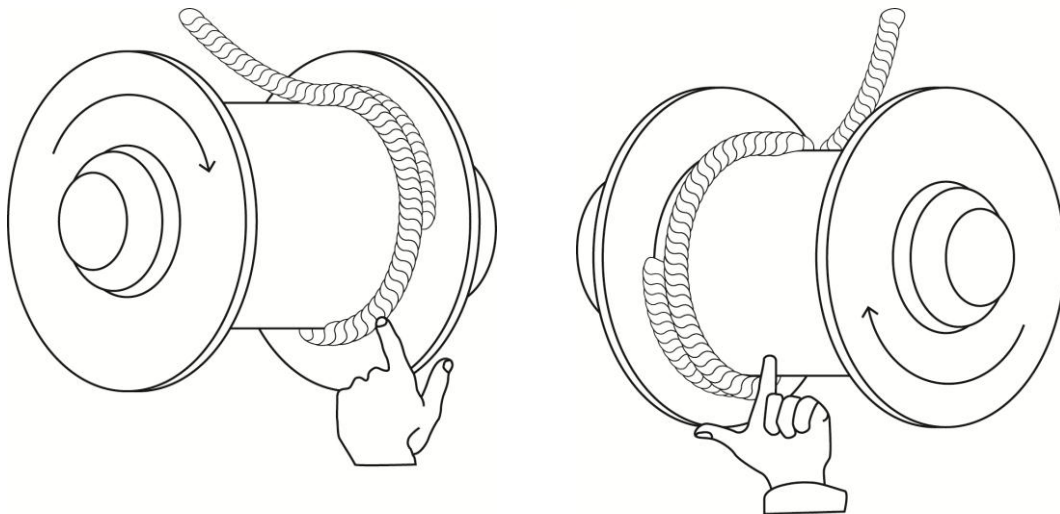

(C) LH LAY ROPE OVERWOUND

(D) LH LAY ROPE UNDERWOUND

Figure 40: Examples of lay rope

The rope must be anchored to the drum with a fixed mechanical anchorage. Be aware of the danger of not properly tightening an anchorage. Do not rely on the frictional grip relayed by the three turns on the drum.

Comply with the manufacturer's recommendation about whether drums are overwound or underwound. If a drum is wound incorrectly, it can affect the anchorage, brake and drive mechanism to the drum, resulting in mechanical failure. The lay of the rope and whether the drum is overwound or underwound determines where the rope is to be anchored.

Be especially careful when raising very heavy loads to a great height, such as with long boom mobile cranes. The amount of turns on the drum determines the drum diameter. As the diameter increases, the torque to the drive mechanism and brake increases. As a result, the higher the load is raised the faster it is raised, and more difficult to control.

The top layer on a multi-layered drum must not be closer than the manufacturer's recommendation to the top of the flange when the drum is full.

Fleet angles

The maximum fleet angle is measured from the centre of the drum to the centre of the first diverting sheave then back to the inside flange at the middle of the drum.

The maximum fleet angle for a grooved drum is 5° and for an ungrooved drum is 3°. To achieve these angles, the distance from the drum to the first diverting sheave must be a minimum of:

- (a) 19 times half the width of the drum for an ungrooved drum
- (b) 12 times half the width of the drum for a grooved drum.

Example 1:

Width of the grooved drum = 1 metre

$$12 \times 1 \times 0.5 = 6$$

Therefore, the sheave must be 6 metres from the drum.

FLEET ANGLE

HOIST DRUM

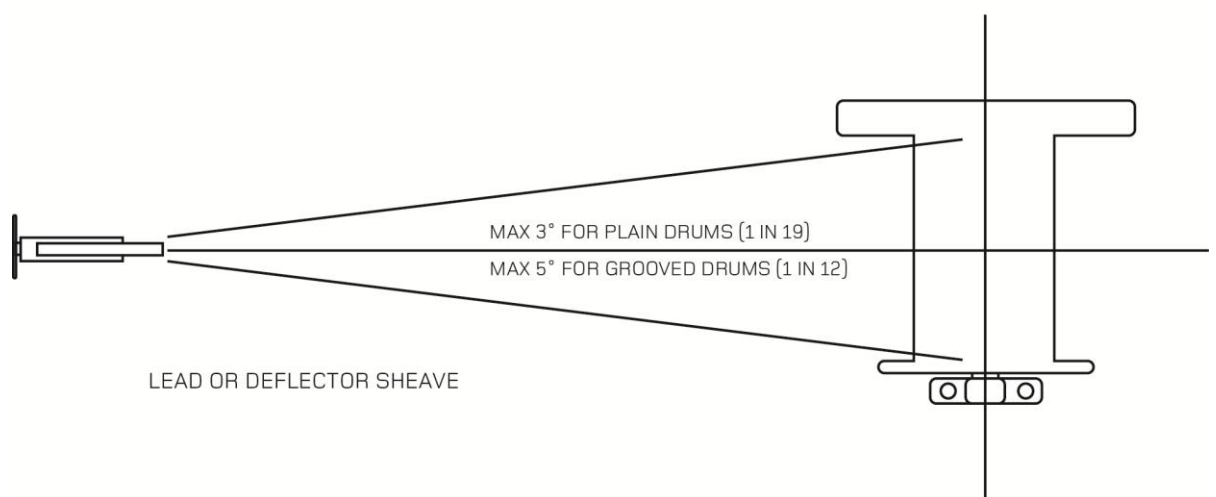

Figure 41: Grooved drum calculation example

Example 2:

Width of the ungrooved drum = 1 metre

$$19 \times 1 \times 0.5 = 9.5$$

Therefore, the sheave must be 9.5 metres from the drum.

If the fleet angle is too large or the distance between the drum and the first lead or diverting sheave is too short, the rope will not lay neatly on the drum and will create severe wear on the rope and the sheave flange.

Safe loads on wire rope purchases of a temporary nature

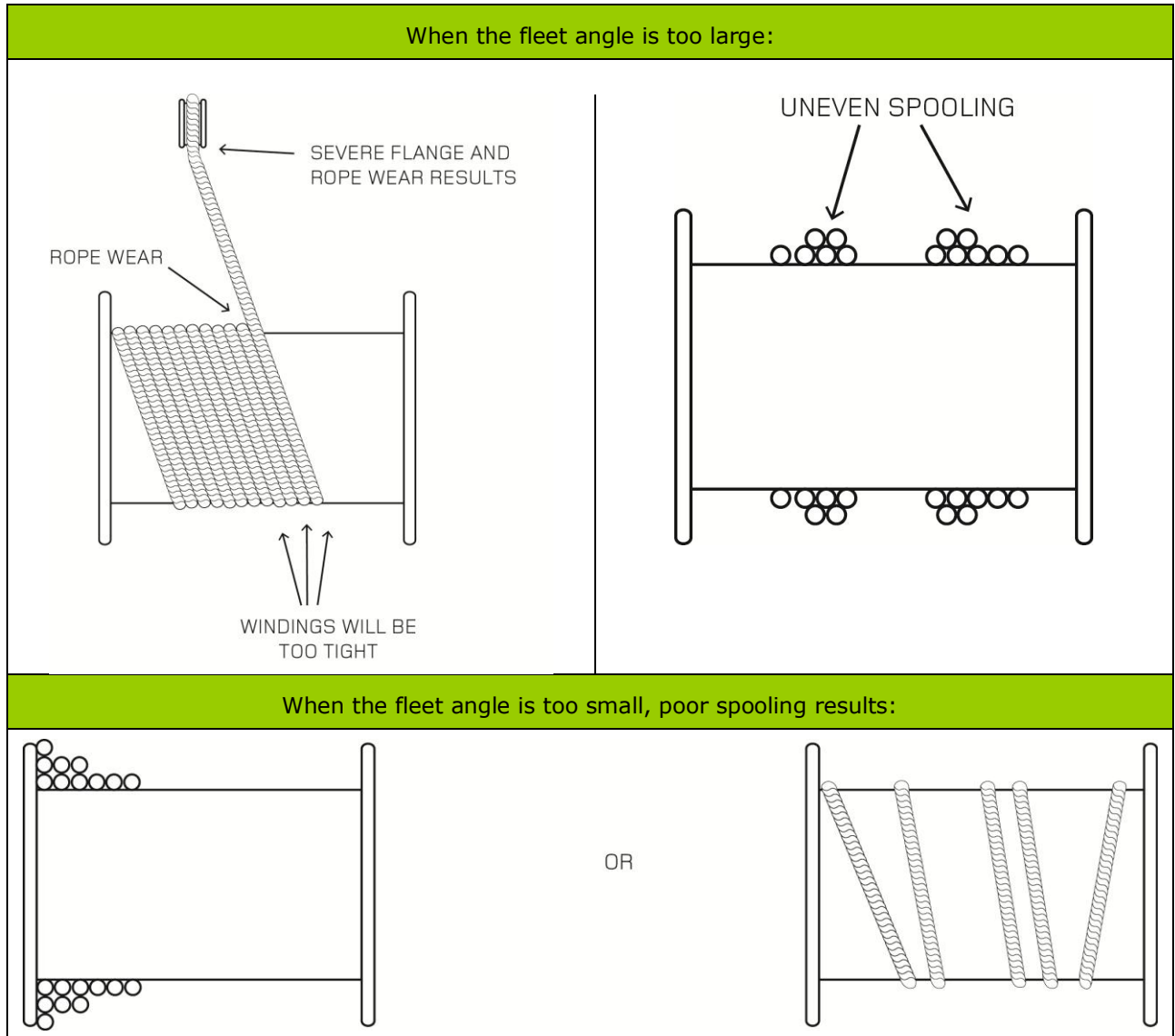

Figure 42: Effect of fleet angle on spooling

Figure 43 indicates the number of running sheaves in each pulley block.

Tabulated safe loads allow for an extra (lead) sheave (not shown in diagrams).

P = Pull in the lead rope (as fixed by the size of the rope) - t

D = Minimum diameter at bottom of groove of sheave - mm

W = Safe load that may be lifted. Parts of rope supporting load - tonnes

Rope
Size Diameter
Mm

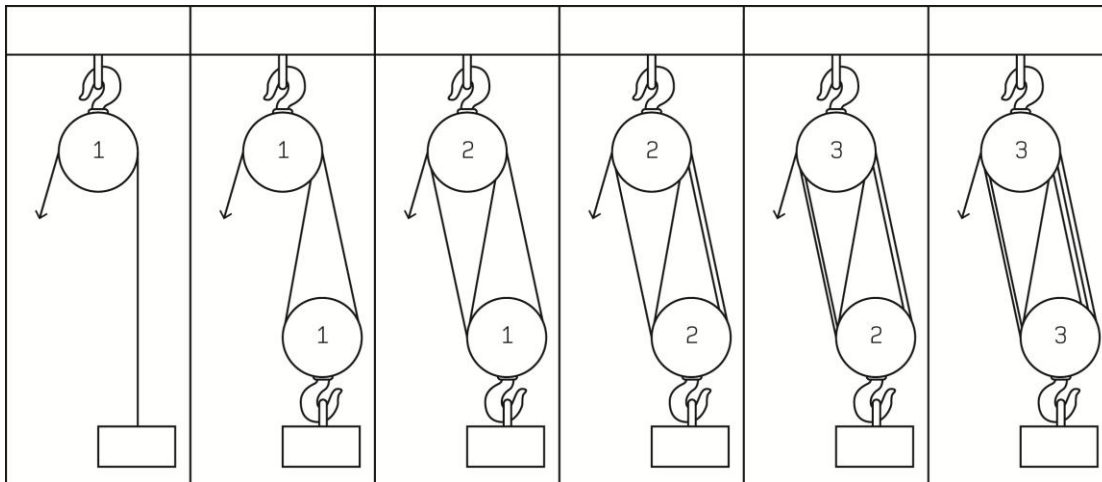

Figure 43: Number of running sheaves in each pulley block

Table 22: Tabulated safe loads

D mm P T	Parts of Rope	Supporting Load	Tonnes W					
			1	2	3	4	5	6
8	120	0.825	0.790	1.542	2.26	2.96	3.62	4.26
9	135	1.03	0.988	1.93	2.83	3.69	4.52	5.31
11	165	1.55	1.48	2.89	4.26	5.56	6.80	8.00
13	195	2.16	2.05	4.04	5.94	7.75	9.48	11.15
16	240	3.28	3.11	6.13	9.02	11.77	14.40	16.92
19	285	4.62	4.39	8.63	12.70	16.58	20.28	23.83
20	300	5.14	4.88	9.61	14.13	18.45	22.56	26.52
22	330	6.20	5.89	11.59	17.05	22.26	27.22	32.00
26	390	8.66	8.22	16.19	23.81	31.09	38.02	44.68
28	420	10.06	9.56	18.81	27.66	36.11	44.16	51.90
32	480	13.14	12.48	24.57	36.13	47.17	57.68	67.80

Based on bronze sheaves for friction loss.

Note: The masses in table 22 must not exceed those marked on the blocks as being the safe mass that may be lifted. Most blocks are limited by the size of hooks and other components and not the number of falls of rope. A factor for friction has been added.

- The WLL together with any conditions of loading deemed necessary for safe use is to be stamped or otherwise marked on each block.
- Sheave diameters measured at the bottom of the groove may be as follows (temporary use only):
 - For power-operated blocks: 15 x rope diameter.
 - For hand-operated blocks: 10 x rope diameter.

6.11.4 Purchases

A wire rope reeved through sheaves to obtain a mechanical advantage is known in rigging as a 'purchase'.

Purchase and lead blocks should have the close-fitting cheeks pattern, or be the dished type where the sheave is recessed into cheeks.

Snatch blocks

Snatch blocks should always be carefully watched; the gate must be properly closed and the split pin inserted and open.

Snatch blocks should incorporate a locking pin of positive type not requiring the use of any tool for its effective positioning. A drop nose pin used as a hinge pin is recommended, and the locking device must be strongly made and suitable for the intended use of the block.

Sheave blocks

Twisting would cause the rope to jam or ride on the rim of the sheave, and slip between the sheave and the cheek plate, jamming and destroying the rope.

Reverse bends

Avoid reverse bends because they cause much greater fatigue than if all bends were made in the one direction.

A rope running in one direction over one sheave and then in a reverse direction (i.e. 'S' fashion) over another sheave will suffer early fatigue and deterioration. As the rope passes over a sheave it is bent, and as it leaves the sheave it is straightened, two distinct actions causing fatigue. This is made worse if the rope, after being bent in one direction, is then straightened and again bent in an entirely opposite direction over another sheave after which it is again straightened.

Multiple layers on drums

If a load is to be lifted to a height where multiple layers must be laid onto a drum, several safety precautions should be taken.

Independent steel wire cored ropes should be used to prevent crushing.

The drum must have the capacity to take the amount of rope. The bottom layers must be tightly and neatly laid onto the drum.

Capacity of drums and storage reels

There is a formula for determining the amount of rope that can be stored on a storage reel. This formula can be used when determining whether the winch drum has sufficient capacity to take the amount of rope needed in a purchase.

Length of rope that can be stored on a reel/drum/barrel

$$\text{Capacity } L \text{ in metres} = (A + D) \times A \times C \div 1000 \times K$$

- Where:
- L = Length of rope in metres.
 - A = Depth of reel/drum/barrel flange in mm
 - D = Diameter of reel/drum/barrel in mm
 - C = Distance between flanges in mm
 - K = A multiplying factor for various rope diameters (see table).

LENGTH OF ROPE THAT CAN BE
STORED ON A REEL

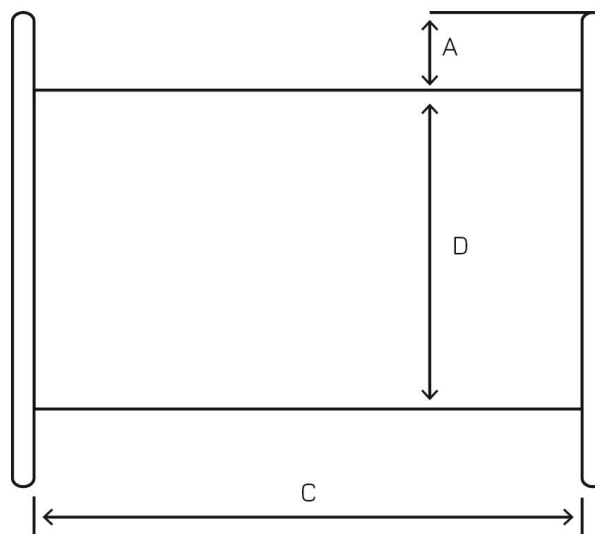

ROPE STORAGE REELS

Figure 44: Determining the capacity of a reel for rope storage

Table 23: Tabulated method

Rope Diameter mm	Multiplier "K"	Rope Diameter mm	Multiplier "K"
6	11.2	36	400
10	31	40	500
12	45	44	600
16	80	48	720
20	125	52	840
24	180	56	980
28	240	60	1120
32	315	-	-

Alternative Method

$$\text{Rope Length (m)} = \frac{(A+B) \times A \times C \times \mu \times 10^6}{D^2}$$

Where A, B and C are quoted in metres and D in millimetres.

6.11.5 Cable pulling stockings

Cable pulling stockings are used for reeving wire ropes through purchases and for fitting cables in various places where the opening or access is restricted.

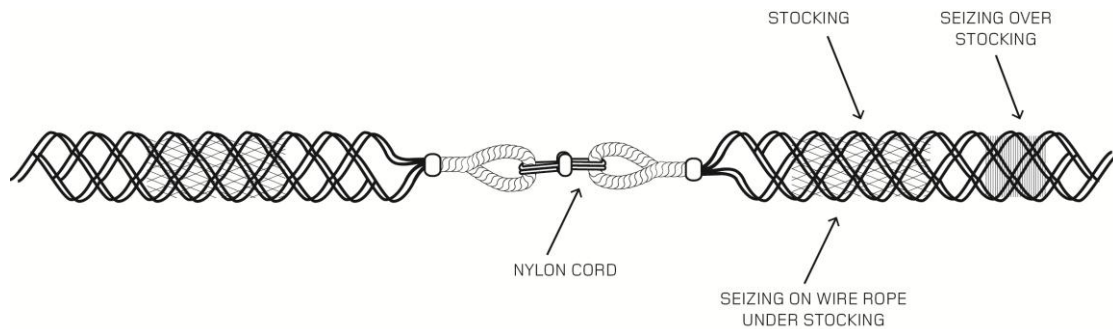

Figure 45: Cable pulling stockings

They are especially useful where the boom head, luff drum, and hoist winch of tower cranes are high above the ground.

A fibre rope is reeved and attached to the drum, and then is attached to the rope, which is fitted with a cable pulling stocking. The rope is then pulled through the system by the fibre rope.

Cable pulling stockings must not be used for load lifting purposes.

6.11.6 Seizings

It is most important that tight seizings of annealed iron wire or strands be maintained on the ends of ropes, whether preformed or not. If ropes are not properly seized prior to cutting, wires and strands are apt to become slack with consequent upsetting of uniformity of tensions in the rope. This could result in overloading of some wires and

strands and under-loading of others, leading to the occurrence of high strands, bird caging of wires, or breakage of wires and strand.

Rotation resistant ropes, regardless of their construction, depend on retention of built-in torsional balance for their ability to resist rotation under load. Therefore, it is essential that the seizing practice as described below and in the accompanying diagram be carefully followed.

Seizing rotation-resistant ropes

Ropes must be served tightly on each side of the position where they are required to be cut. The length of each serving should be equal to two rope diameters. For multi-strand and rotation resistant ropes, two servings on each side of the cut are recommended and after cutting, the rope end must be welded up across its section so that all the wires and strands are completely secured.

It is recommended, where possible, that the rope be fused and tapered by the supplier.

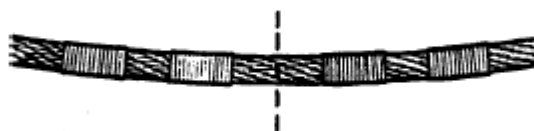
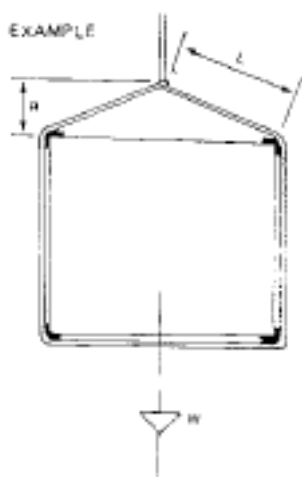

Figure 46: Cutting a rotation-resistant rope

6.11.7 Tension in each sling leg

Note: The greater the included angle of "A" the greater the load in the sling legs.



Example:

- T = Tension in rope in each sloping leg.
- L = Length of each leg.
- R = Rise
- W = Load to be lifted.

$$T = \frac{1/2 W \times L}{R}$$

Figure 47: Calculating tension for sling legs

Example: If load = 2 tonnes:

L = 675mm

R = 300mm

Then $T = \frac{0.5 \times 2000\text{kg} \times 0.675}{0.3000}$

= 2.25 tonnes.

Therefore, because of reeving, select sling for: $2 \times 2.25 = 4.5$ tonnes.

6.12 Rigging blocks

6.12.1 Multiplication factors for snatch block loads

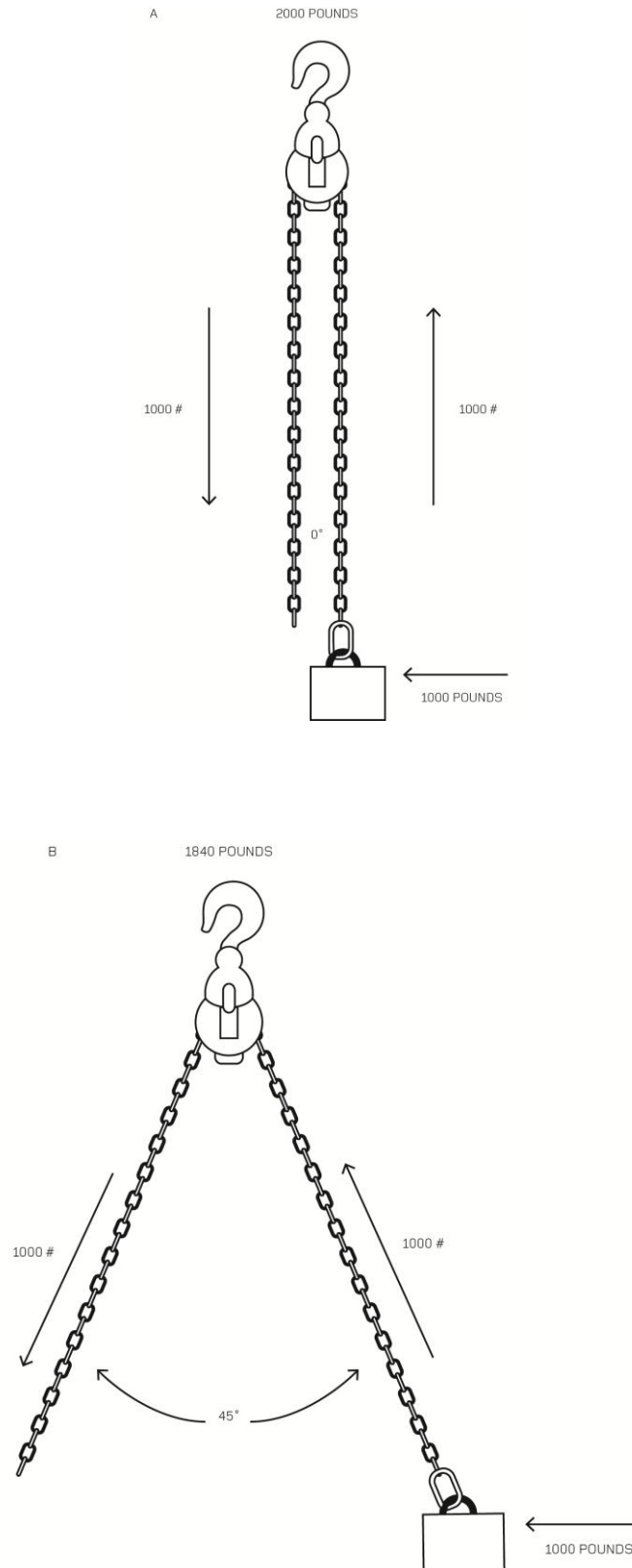

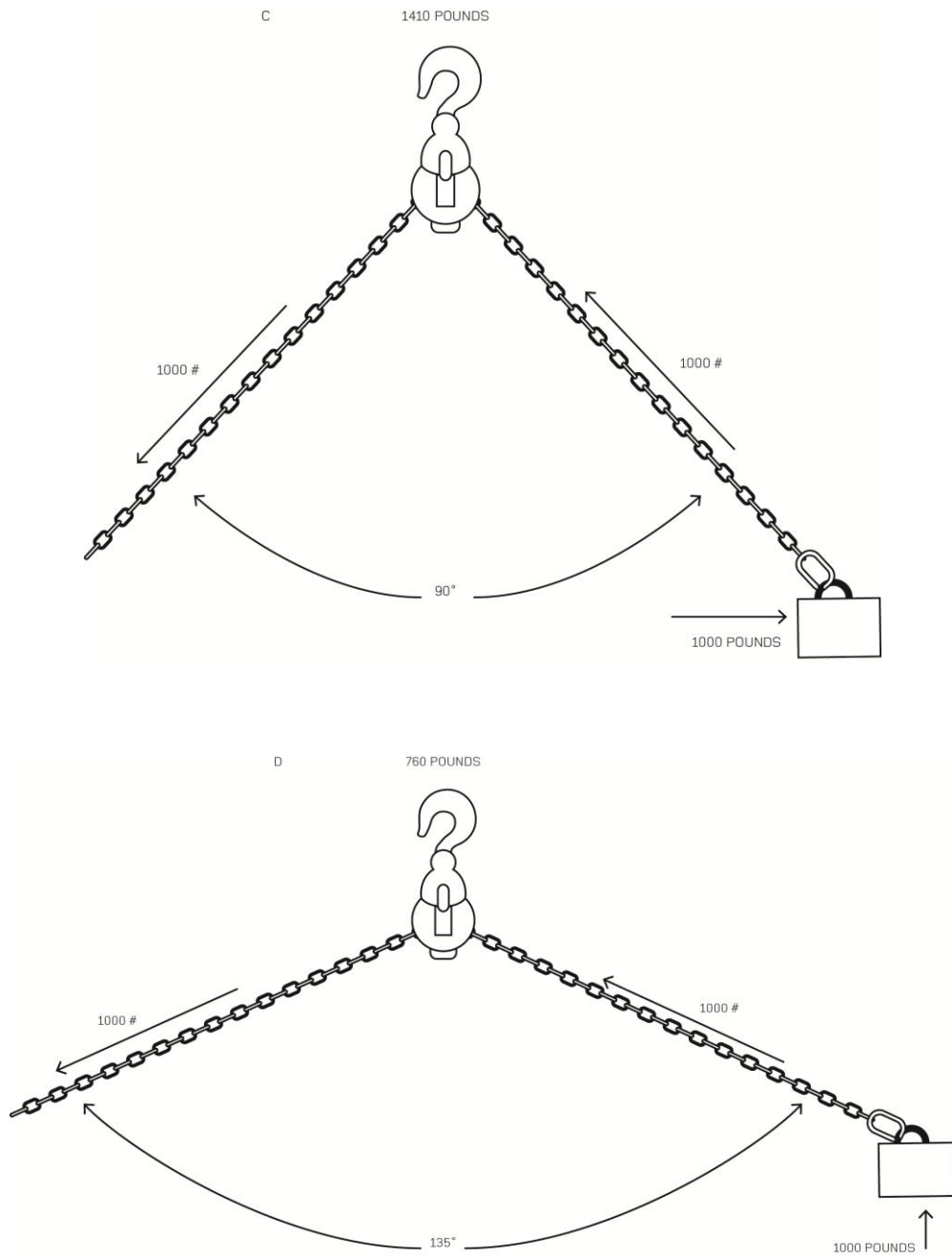

Figure 48: Multiplication factors for snatch block loads

Table 24: Multiplication factors for snatch block loads

Angle Between Lead and Load Lines (°)	Multiplication Factor
10	1.99
20	1.97
30	1.93
40	1.87
50	1.81
60	1.73
70	1.64
80	1.53
90	1.41
100	1.29
110	1.15
120	1.00
130	0.84
140	0.68
150	0.52
160	0.35
170	0.17
180	0.00

6.12.2 High line tension by formula

The total weight is the combined weight of the load plus the hoist line pull.

The tension formula is: $T_1 = \text{Load} \times D_2 S_1 / H(D_1 + D_2)$

$T_2 = \text{Load} \times D_1 S_2 / H(D_1 + D_2)$

(Use softeners when lifting from building structural steel).

Equation 1: High line formula example

Weight = 3,000kg
 Pull = 3,000kg
 Total Load = 6,000kg

$S_1 = 10.1$
 $S_2 = 4.1$
 $D_1 = 10$
 $D_2 = 4$
 $H_1 = 1$

$T_1 = \text{Load} \times D_2 S_1 / H(D_1 + D_2)$
 $T_1 = 6,000 \times 4 \times 10.1 / 1 (10 + 4)$
 $T_1 = 242,400 / 14 = 17,314$

The left side tension is 17,314kg.

$$T_2 = \text{Load} \times D_1 S_2 / H (D_1 + D_2)$$

$$T_2 = 6,000 \times 10 \times 4.1 / 1 (10 + 4)$$

$$T_2 = 246,000 / 14 = 17,571$$

The right side tension is 17,57kg.

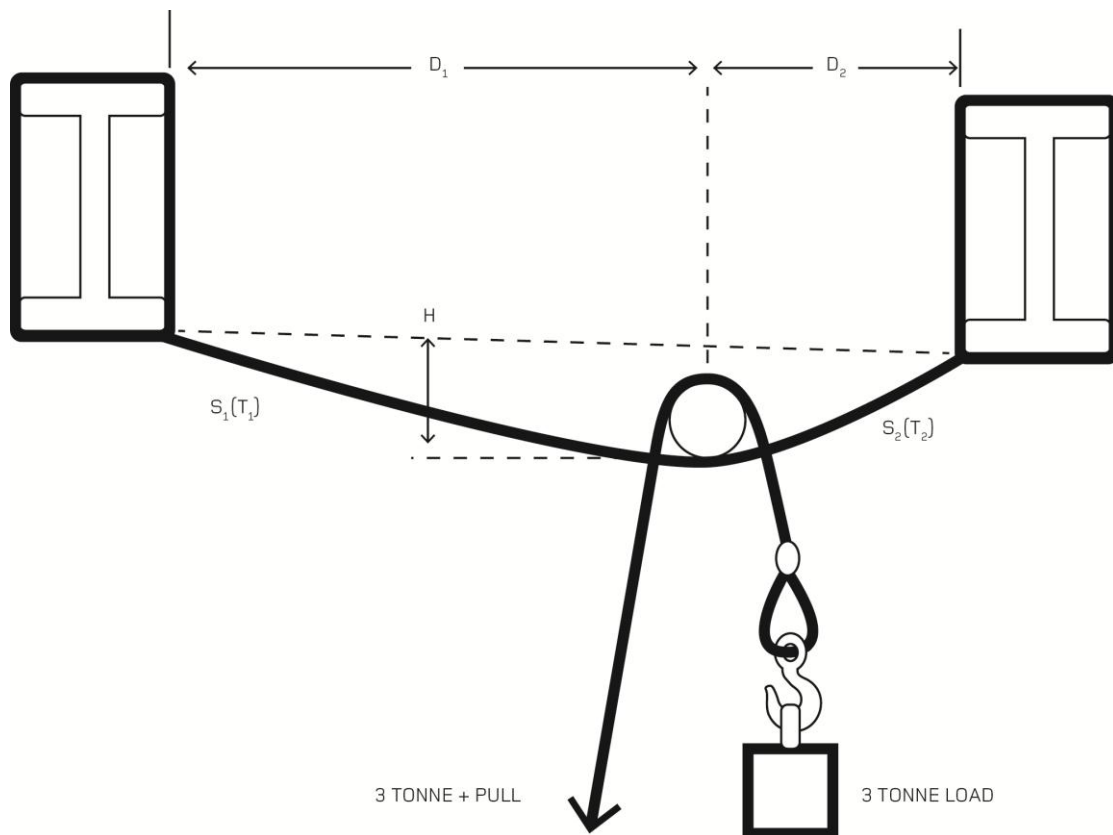

Figure 49: Tension on two falls drifting a load

6.12.3 Fall tension formula

The tension on two falls drifting a load can be enough to overload them. Calculating the tension uses the same method as that used for a high line.

Fall (or come-a-long) tension will vary when a load is lifted, then drifted over to another location. The tension on each chain fall can be worked out by formula for various positions.

Equation 2: Example tensions while drifting a load

$$T_1 = \text{Load} \times D_2 S_1 / H (D_1 + D_2)$$

$$T_2 = \text{Load} \times D_1 S_2 / H (D_1 + D_2)$$

$$\text{Load on fall B (initial position 1)} = 1000\text{kg}$$

$$\text{Load on fall A (final position 3)} = 1000\text{kg}$$

$$S_1 = 6.152 = 12.3$$

$$D_1 = 3.8D_2 = 11.4$$

$$H = 4.7$$

$$\text{Fall A (position 2)} = \text{Load} \times D_2 S_1 / H(D_1 + D_2)$$

$$\text{Fall A} = 1000 \times 11.4 \times 6.1 / 4.7 (3.8 + 11.4)$$

$$\text{The tension on fall A} = 69540 / 71.44 = 973 \text{kg}$$

$$\text{Fall B (position 2)} = \text{Load} \times D_1 S_2 / H(D_1 + D_2)$$

$$\text{Fall B} = 1000 \times 3.8 \times 12.3 / 4.7 (3.8 + 11.4)$$

$$\text{The tension on fall B} = 46740 / 71.44 = 654 \text{kg.}$$

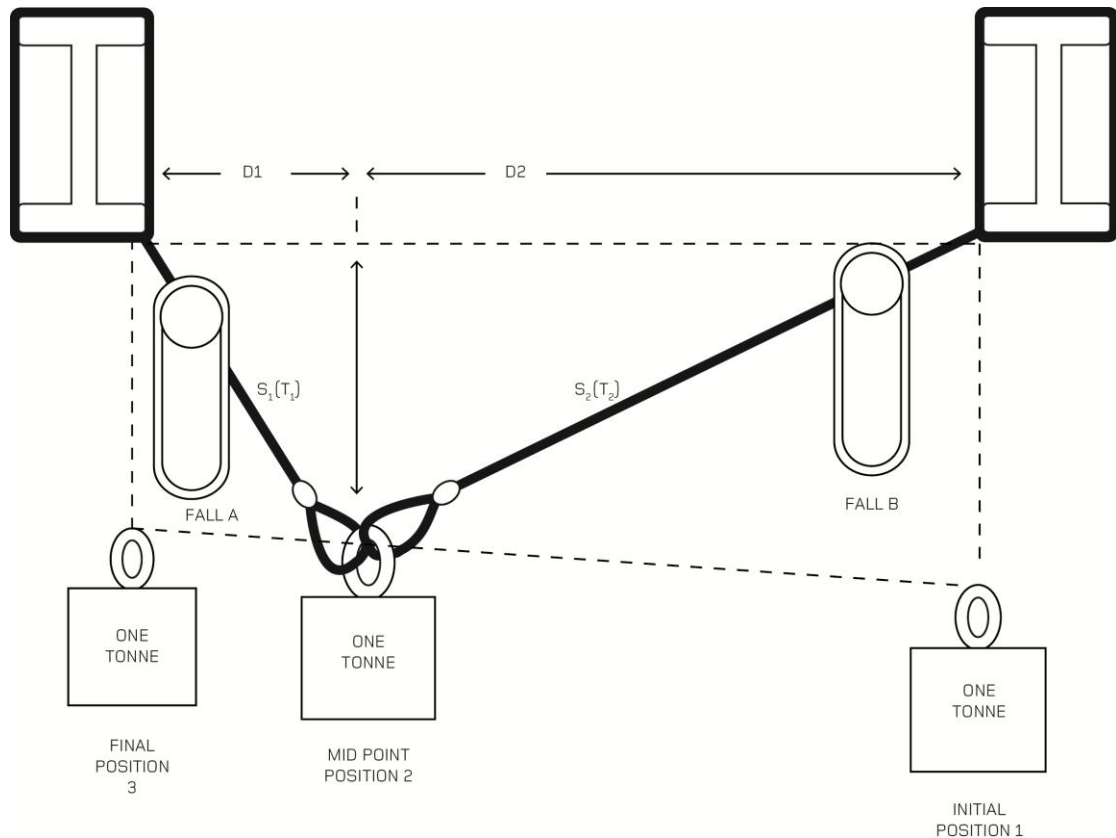

Figure 50: Drifting a load

Note: The above formula is based on both falls being positioned at the same elevation.

6.13 Handling steel plate

Certified equipment should be used at all times.

Steel plate can be lifted with:

- plate clamps that are designed to increase the purchase on the plate as the plate is lifted
- hooks or shackles where there are lifting holes in the plate.

Do not use home-made type plate clamps or plate dogs.

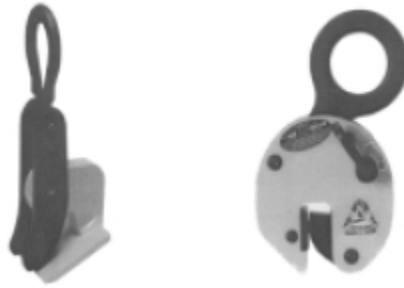

Figure 51: Examples of plate clamps

6.13.1 Examples of types of plate clamps

Plate clamps should be used as per manufacturer's recommendations, for example, hardness of plate.

A spreader beam must be used if the angle between the two legs is likely to be more than 60°.

6.13.2 Pallets

A wide variety of loads are delivered on pallets. Before a palletised load is lifted from a truck, check that:

- The pallet is free from defects; and
- The load is secured so that nothing can fall off.

Pallets should be constructed to *AS/NZS 2010: Specification for flat pallets for materials handling*. The pallet supplier should be able to verify this.

6.13.3 Turning over loads

When turning over a load, such as a steel beam, the sling must be attached to the hook on the side of the load that is to be lifted. This will ensure that it will be raised on a diagonal through the centre of gravity.

It is then a simple matter to lower the hook, turning the beam over in a safe and controlled manner.

It is important that the beam is slung so that when the beam is lowered the nip will pull against the eye.

Structural steel members such as universal beams and RSJs have a high centre of gravity and a narrow base when standing on their flange. If a sling is nipped incorrectly the beam will flop, topple over and possibly break the slings.

The same principles apply when turning over all loads.

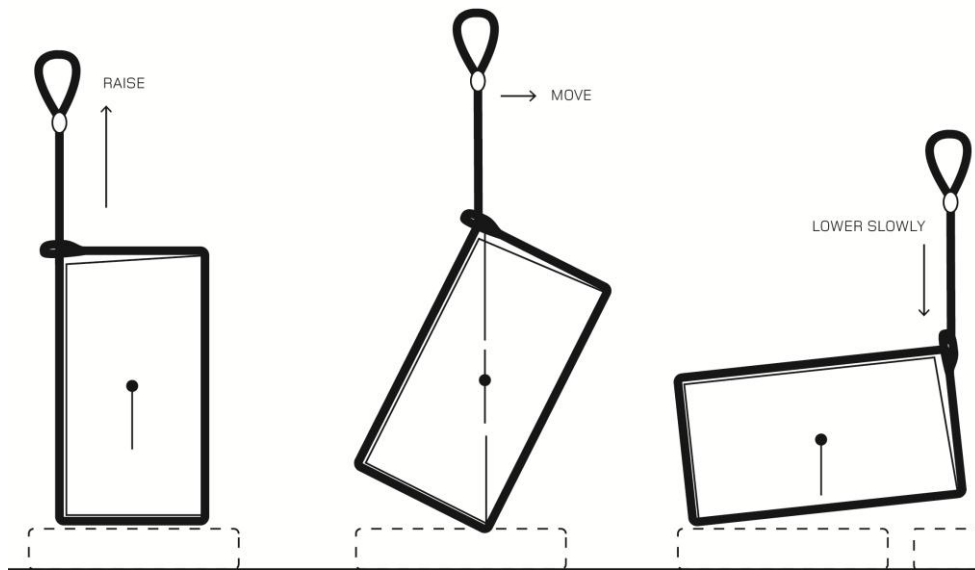

Figure 52: Correct method of turning over a load

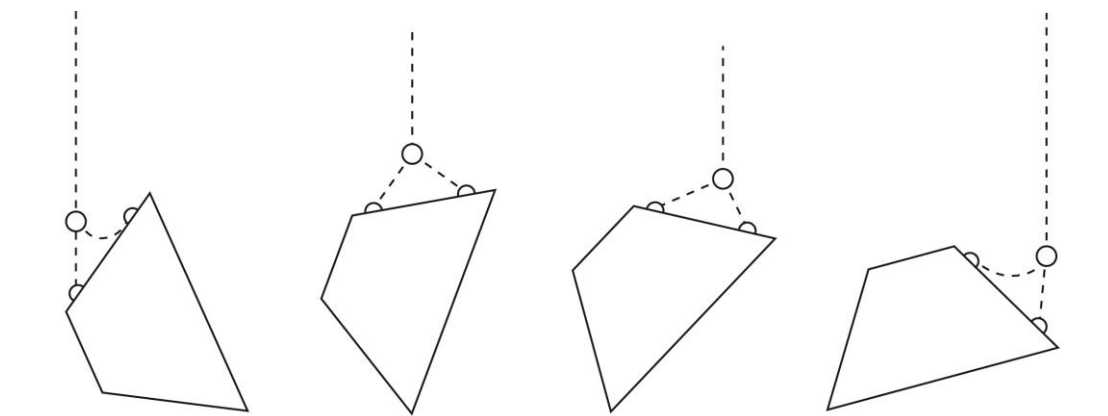

Figure 53: Correct method of turning over a steel bin

APPENDIX 1: THE HEALTH AND SAFETY IN EMPLOYMENT ACT 1992

Note: the following information is a summary of extracts of the Health and Safety in Employment Act 1992. Copies of this Act can be obtained from the *New Zealand Legislation* website at www.legislation.govt.nz.

Object of the Act

The object of the Health and Safety in Employment Act 1992 (the HSE Act) is to promote the prevention of harm to all people at work and people in the vicinity of a place of work. To do this, the Act:

- promotes excellence in health and safety management;
- defines harm and hazards in a comprehensive way;
- imposes duties on those who are responsible for work, or do work;
- sets requirements to take all practicable steps to ensure employee health and safety that are flexible to cover different circumstances; and
- requires employee participation in health and safety management, and that the process is conducted in good faith by all those involved.

Reference: Section 5 Health and Safety in Employment Act 1992.

The Act creates duties for most people connected with places of work, including:

- employers;
- employees (including trainees, people gaining work experience and volunteers);
- the self-employed;
- principals to contractors;
- persons who control a place of work; and
- hirers, sellers and suppliers of plant.

Regulations

Regulations are promulgated from time to time under the HSE Act. Regulations may, among other things, impose duties on employers, employees, designers, manufacturers, principals, self-employed persons, and others relating to health and safety. These regulations may apply with respect to places of work, plant, processes or substances and may deal with particular problems that have arisen.

Reference: Section 21 Health and Safety in Employment Act 1992.

The Health and Safety in Employment Regulations 1995 require the provision of facilities such as toilets, first aid, for employees to wash, a place to have meals and the provision of wholesome and sufficient drinking water. The regulations also set a range of general health, safety and welfare requirements in addition to the Act, including:

- restricting young people from certain hazardous work and times of work;
- requiring certification of workers using some hazardous equipment;
- requiring notification of particular types of hazardous work, including forestry and construction; and
- creating duties for the designers, manufacturers and suppliers of plant and protective clothing and equipment.

Reference: Health and Safety in Employment Regulations 1995.

Approved Codes of Practice

Approved Codes of Practice are provided for in the HSE Act. They are statements of preferred work practice or arrangements, and may include procedures which could be taken into account when deciding on the practicable steps to be taken to ensure safety in the workplace.

Compliance with Approved Codes of Practice is not mandatory; however, compliance with Approved Codes of Practice may be used in Court as evidence of good practice of an employer or other duty holder having taken "all practicable steps" to meet their duty.

If a person has not adopted the method prescribed in the Approved Code, it is up to that person to ensure that the legal requirement has been met by an alternative method.

Reference: Section 20 Health and Safety in Employment Act 1992.

Employers' duties

Employers have duties to ensure the health and safety of employees at work.

Employers have a general duty to take all practicable steps to ensure the safety of employees while at work. In particular, they are required to take all practicable steps to:

- provide and maintain a safe working environment;
- provide and maintain facilities for the safety and health of employees at work;
- ensure that machinery and equipment are safe for employees;
- ensure that working arrangements are not hazardous to employees; and
- provide procedures to deal with emergencies that may arise while employees are at work.

Reference: Section 6 Health and Safety in Employment Act 1992.

Taking "all practicable steps" means doing what is reasonably able to be done in the circumstances, taking into account:

- the severity of any injury or harm that may occur;
- the degree of risk or probability of that injury or harm occurring;
- how much is known about the hazard and the ways of eliminating, reducing or controlling it; and
- the availability, effectiveness and cost of possible safeguards.

A person is required to take all practicable steps in respect of circumstances that they know or ought reasonably to know about.

Reference: Section 2A Health and Safety in Employment Act 1992.

Hazard management

Employers must identify and regularly review existing, new and potential hazards in the place of work to determine whether they are significant hazards and thus require further action. If an accident or harm occurs that requires its particulars to be recorded,

employers are required to investigate it to determine if it was caused by or arose from a significant hazard.

Reference: Section 7 Health and Safety in Employment Act 1992.

“Significant hazard” means a hazard that is an actual or potential cause or source of:

- serious harm (defined in Schedule 1 of the Act); or
- harm (being more than trivial) where the severity of any person’s effects depend (entirely or among other things) on the extent or frequency of the person’s exposure to the hazard; or
- harm that does not usually occur, or is not easily detectable, until a significant time after exposure to the hazard.

Where the hazard is significant, the HSE Act sets out the steps employers must take:

- Where practicable, the hazard must be eliminated.
- If elimination is not practicable, the hazard must be isolated.
- If it is impracticable to eliminate or isolate the hazard completely, then employers must minimise the likelihood that employees will be harmed by the hazard.

Reference: Sections 8, 9 and 10 Health and Safety in Employment Act 1992.

Where the hazard has not been eliminated or isolated, employers must, where appropriate:

- provide protective clothing and equipment and ensure that it is accessible and used by employees;
- monitor employees’ exposure to the hazard;
- seek the consent of employees to monitor their health; and
- with informed consent, monitor employees’ health.

Reference: Section 10 Health and Safety in Employment Act 1992.

Employers are also required to inform employees of the results of any health and safety monitoring. In doing so, the privacy of individual employees must be protected.

Reference: Section 11 Health and Safety in Employment Act 1992.

Information for employees and health and safety representatives

Before employees begin work, they must be informed by their employer, in a manner that the employees are reasonably likely to understand, of:

- hazards employees may be exposed to while at work;
- hazards employees may create which could harm themselves or other people;
- how to minimise the likelihood of those hazards becoming a source of harm to themselves and others;
- the location and correct use of safety equipment; and
- emergency procedures.

Where employee health and safety representatives are present, the employer must ensure that the representatives have ready access to sufficient information about health

and safety systems and issues in the place of work to enable them to be able to carry out their functions effectively.

Reference: Section 12 Health and Safety in Employment Act 1992.

Training and supervision of employees

An employer must ensure that every employee who:

- does work of any kind, or
- uses plant of any kind, or
- deals with a substance of any kind

in a place of work has the knowledge and experience – or is supervised by someone who has – so that they are not likely to suffer harm, or lead to the harm of others.

Every employee must be adequately trained in the safe use of all plant, objects, substances, protective clothing and equipment that they are, or may be, required to use or handle.

Reference: Section 13 Health and Safety in Employment Act 1992.

Responsibility for employees' work activities

An employer is also responsible for the health and safety of others arising from the work activities of their employees. They must take all practicable steps to ensure that no action or inaction of an employee while at work causes harm to any other person.

Reference: Section 15 Health and Safety in Employment Act 1992.

Persons in control of a place of work

The Act places duties on persons who control a place of work in relation to people in the vicinity, and to visitors.

A "person who controls a place of work" includes a person who owns, leases, subleases or occupies a place of work, or who owns, leases or subleases plant or equipment used in a place of work.

Reference: Section 16 Health and Safety in Employment Act 1992.

Duties of the self-employed

Every self-employed person shall take all practicable steps to ensure that no action or inaction of theirs while at work harms themselves or any other person.

Reference: Section 17 Health and Safety in Employment Act 1992.

Duties of principals

Principals engaging contractors are required to take all practicable steps to ensure that:

- no employee of a contractor or subcontractor, or
- if an individual, no contractor or subcontractor

is harmed while doing any work (other than residential work) that the contractor was engaged to do.

Reference: Section 18 Health and Safety in Employment Act 1992.

Note: subcontractors are generally either self-employed or employees of an employer. These people have legal responsibilities to ensure their own health and safety and that of others under sections 17 and 19 of the Act respectively.

Hirers, sellers and suppliers of plant

The Act places duties on people to ensure that any plant or equipment that is used in a place of work is designed and made, and has been maintained, so that it is safe for its intended use. The duties apply to people who:

- hire, lease or lend plant to another person that could be used in a place of work;
- sell or supply plant (other than for hire, lease or loan); or
- install or arrange plant in addition to either of the above.

This section does not apply to the sale of second-hand plant and plant sold "as is".

Reference: Section 18A Health and Safety in Employment Act 1992.

Duties of employees

Every employee shall take all practicable steps to ensure:

- their own safety while at work (including using protective clothing and equipment), and
- that no action or inaction of theirs while at work causes harm to any other person.

Reference: Section 19 Health and Safety in Employment Act 1992.

An employee has a right to refuse to undertake work that they consider likely to cause them serious harm. However, employees have an obligation to attempt to resolve the matter with their employer prior to taking action.

Reference: Section 28A Health and Safety in Employment Act 1992.

Deemed employees

People receiving on-the-job training, work experience or loaned employees are all deemed to be "employees" of an employer or self-employed person for whom they are working. In this situation most duties imposed on employers under the Act also apply to deemed employees, except for the duty to provide for employee participation.

Reference: Sections 3E and 3F Health and Safety in Employment Act 1992.

Employers to provide opportunities for employee participation

Employers must provide reasonable opportunities for employees to participate effectively in on-going processes for the improvement of health and safety in the place of work.

Where there are more than 30 employees, or where an employee or union representing employees requests it, the employer must seek agreement to, develop, implement and

maintain a system of employee participation. Where agreement cannot be reached on the system of employee representation, there are default provisions set out in the Act.

Where employee health and safety representatives are elected, they are entitled to paid leave to attend approved training courses.

A trained employee health and safety representative may issue a hazard notice to an employer where they believe there is a hazard in the place of work, they have brought it to the employer's attention and the issue has not been resolved.

Employers and employees must deal with each other in good faith while seeking agreement on, developing and maintaining a system of employee participation.

Reference: Part 2A and Schedule 1A Health and Safety in Employment Act 1992.

Accidents and serious harm recording and notification

The Act requires employers, the self-employed and principals to contractors to keep a register of work-related accidents and serious harm.

For employers, this includes every accident that harmed (or might have harmed):

- any employees at work, or
- any person in a place of work controlled by the employer.

Reference: Section 25 Health and Safety in Employment Act 1992.

Employers are also required to investigate all accidents, harm and "near misses" to determine whether they were caused by a significant hazard.

Reference: Section 7 Health and Safety in Employment Act 1992.

Any occurrences of serious harm of a kind that must be recorded shall also be notified to the Secretary of Labour (in practice, the nearest Ministry of Business, Innovation and Employment office) as soon as possible after the occurrence becomes known to the employer. In addition, the accident must also be reported on the prescribed form within seven days.

Forms are available from the Ministry of Business, Innovation and Employment's website: www.osh.govt.nz/order/catalogue/forms.shtml

If a person suffers serious harm, the scene of the accident must not be interfered with unless to:

- save the life of, prevent harm to or prevent suffering to, any person; or
- maintain public access for essential services, for example, electricity, gas; or
- prevent serious damage or loss of property.

A Health and Safety Inspector will advise whether the Ministry of Business, Innovation and Employment will investigate the accident and whether any action may be taken in the meantime.

Reference: Section 26 Health and Safety in Employment Act 1992.

APPENDIX 2: THE HEALTH AND SAFETY IN EMPLOYMENT REGULATIONS 1995

Note: the following information is a summary of extracts of the Health and Safety in Employment Regulations 1995. Copies of these Regulations can be obtained from the *New Zealand Legislation* website at www.legislation.govt.nz.

General duties of employers

The Health and Safety in Employment Regulations 1995 extend the provisions of section 6 of the Act in relation to the provision of facilities such as toilets, first aid, washing, and the provision of wholesome and sufficient drinking water.

Reference: Regulations 4 to 9 Health and Safety in Employment Regulations 1995.

Managing specific hazards

The regulations also place duties on employers in relation to specific hazards. In respect of rigging work, the most relevant regulations are as follows:

Working under raised objects

If an employee is working under any thing that has been raised or lifted, supports or other devices meant to prevent the object from falling or being lowered onto the worker are required.

Reference: Regulation 16 Health and Safety in Employment Regulations 1995.

Heights of more than three metres

This regulation requires employers to take all practicable steps to ensure that, where any employee may fall more than three metres, then:

- means are provided to prevent the employee from falling; and
- any means so provided are suitable for the purposes for which they are to be used.

Reference: Regulation 21 Health and Safety in Employment Regulations 1995.

Note: Regulation 21 is the source of the often-quoted “three metre rule”. It is mistakenly believed that no controls are needed where a person faces a fall of less than three metres. That belief is wrong and ignores the overarching duties in the Health and Safety in Employment Act 1992.

The Act requires that if there is a potential for a person at work to fall from any height, reasonable and practicable steps must be taken to prevent harm from resulting.

Scaffolding

Where construction work cannot be carried out safely without the use of scaffolding, the employer must provide scaffolding that is:

- suitable for the purpose for which it is to be used;
- properly constructed of a sound material;

- able to have sufficient reserve of strength having regard to the loads and stresses that it may be subjected to; and
- sufficient in amount for its purpose.

Reference: Regulation 22 Health and Safety in Employment Regulations 1995.

Notifiable work

Employers must notify the Ministry of Business, Innovation and Employment of any notifiable work that they are to commence with **at least 24 hours** prior to the work commencing.

The notice must be in writing, and contain the following information:

- nature and location of work;
- name, address and contact details of employer;
- intended commencement date of work; and
- estimated duration of work.

The definition of “notifiable work” can be found in section 4.3 of this document.

Notifiable work forms are available from the Ministry of Business, Innovation and Employment website at www.mbie.govt.nz. An online notification form is available at www.osh.dol.govt.nz/tools/HazardousWork/Pages/HazardousWork.aspx

Reference: Regulation 26 Health and Safety in Employment Regulations 1995.

APPENDIX 3: THE HEALTH AND SAFETY IN EMPLOYMENT (PRESSURE EQUIPMENT, CRANES AND PASSENGER ROPEWAYS) REGULATIONS 1999

Note: the following section is an extract of the Health and Safety in Employment (Pressure Equipment, Cranes and Passenger Ropeways) Regulations 1999. Copies of these Regulations can be obtained from the *New Zealand Legislation* website at www.legislation.govt.nz.

Notification duties

Where rigging work is conducted with the use of a crane:

Every controller (of a crane to which the Health and Safety in Employment (Pressure Equipment, Cranes and Passenger Ropeways) Regulations 1999 applies) is required to notify the Ministry of Business, Innovation and Employment as soon as possible after the following occurs:





- an event that causes damage that affects the operational safety of the crane, or
- causes damage to other property that may affect the safety of equipment and might in different circumstances have caused a person to be seriously harmed.





Within seven days of the event occurring, the Ministry shall be given a detailed written investigation report of the circumstances. This investigation shall be carried out by an inspection body or by a chartered professional engineer independent of the controller and the inspection body that carried out the crane's previous inspection.





Reference: Regulation 9 Health and Safety in Employment (Pressure Equipment, Cranes and Passenger Ropeways) Regulations 1999.



APPENDIX 4: CRANE HAND SIGNALS

(Refer to the [Approved Code of Practice for Cranes – Includes the Design, Manufacture, Supply, Safe Operation, Maintenance and Inspection of Cranes](#)).

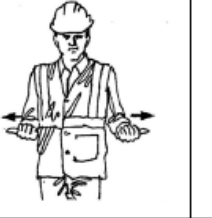
				
<p>STOP Extend one arm and hold palm of hand vertical. Note: EMERGENCY STOP is indicated by holding both arms up.</p>	<p>STOP (B) Arm extended, palm down, move hand right and left. Usually for different level operations.</p>	<p>HOLD EVERYTHING Clasp hands in front of body.</p>	<p>MOVE SLOWLY Place one arm motionless across chest in conjunction with or before giving any other directional signal ("Hoist slowly" shown as example.)</p>	<p>HOIST With forearm vertical, forefinger pointing up, move hand in horizontal circles.</p>

				
<p>LOWER With arm extended downward, forefinger pointing down, move arm in horizontal circles.</p>	<p>USE MAIN HOIST Tap fist on head, then use regular signals.</p>	<p>USE FLYLINE (AUXILIARY HOIST) Tap elbow with one hand, then use regular signals.</p>	<p>RAISE BOOM (LUFF UP) Arm extended, fingers closed, thumb pointing upward.</p>	<p>LOWER BOOM (LUFF DOWN) Arm extended, fingers closed, thumb pointing downward.</p>

				
<p>SLEW Arm extended, point with finger in direction of swing of boom.</p> <p>OVERHEAD GANTRY CRANE – Arm extended, point with finger in the long-travel or cross-travel direction.</p>	<p>RAISE THE BOOM AND LOWER THE LOAD One arm extended, fingers closed, thumb pointing upward. Other arm extended downward with forefinger pointing down, move arm in horizontal circles.</p>	<p>LOWER THE BOOM AND RAISE THE LOAD One arm extended, fingers closed, thumb pointing downward. Other arm vertical with forefinger pointing up, move arm in horizontal circles.</p>	<p>EXTEND HYDRAULIC BOOM OR TROLLEY OUT (TOWER CRANE) Both fists in front of body with thumbs pointing outward.</p>	<p>RETRACT HYDRAULIC BOOM OR TROLLEY IN (TOWER CRANE) Both fists in front of body with thumbs pointing towards each other.</p>

		
<p>TRAVEL Arms bent at the elbows, fists clenched, rotate both forearms around each other, then point in the direction of travel.</p>	<p>TRAVEL (ONE TRACK – CRAWLER CRANES ONLY) Lock the track on the side indicated by the closed fist. Travel opposite track in the direction indicated by the circular motion of other fist rotated vertically in front of body.</p>	<p>FINISHED WITH CRANE Place arms above head and cross hands.</p>

APPENDIX 5: REFERENCE DOCUMENTS

Note: Years of publication for standards have not been listed in this code, as they are subject to change without notice. Please use the most current version available.

New Zealand and Australian standards

NZ and AS/NZS standards can be purchased from Standards New Zealand. Website: www.standards.co.nz.

AS standards can be purchased from SAI Global. Website: <http://infostore.saiglobal.com/Store2/default.aspx>

Number	Title
AS 1353.1	Flat synthetic-webbing slings Part 1: Product specification
AS/NZS 1554.1	Structural steel welding – welding of steel structures
AS/NZS 1554.5	Structural steel welding – Welding of steel structures subject to high levels of fatigue loading
AS/NZS 1800	Occupational protective helmets – Selection, care and use
AS/NZS 1981	Industrial fall-arrest systems and devices (series)
NZS 2010	Specification for flat pallets for materials handling
AS/NZS 2210.1	Occupational protective footwear
AS 4991	Lifting devices
AS 2865	Confined spaces

European and other international standards

BS and BS EN standards can be purchased from the BSI Group (British Standards Institution). Website: www.bsigroup.com.

ISO standards can be purchased from ISO (International Standards Organisation). Website: www.iso.org/iso/home.html

DIN standards in English can be purchased from the Deutsches Institut für Normung e.V. (German Institute for Standards). Website: www.din.de/cmd?level=tpl-home&languageid=en

Federal Specifications can be viewed at the U.S. General Services Administration (GSA). Website: www.gsa.gov/portal/content/100847

ANSI/ASME standards can be purchased from the American National Standards Institute. Website: <http://webstore.ansi.org/>

Number	Title
ANSE/ASME Standards	
ASNSI/ASME B30.9	Slings
British Standards	
BS EN 1263-1	Industrial safety nets – Safety requirements, test methods
BS EN 13157	Cranes. Safety. Hand powered cranes
BS EN 13411-1	Terminations for steel wire ropes. Safety. Thimbles for steel wire rope slings
BE EN 1492-4	Textile slings. Safety. Lifting slings for general service made from natural and man-made fibres
BS EN 1677-5	Components for slings – Safety – Forged steel lifting hooks with latch – Grade 4
BS 2573-1	Rules for the design of cranes. Specification for classification, stress calculations and design criteria for structures
BS 302-5	Stranded steel wire ropes. Specification for ropes for hauling purposes
BS 4-1	Structural steel sections
BS 4278	Specifications for eyebolts for lifting purposes
BS 4429	Specification for rigging screws and turnbuckles for general engineering, lifting purposes and pipe hanger applications
BS MA 47	Code of practice for ships’ cargo blocks
BS 6166	Lifting slings
BS EN 818-4	Short link chain for lifting purposes – Safety – Chain slings – Grade 8.
BE EN 818-7	Short link chain for lifting purposes – Safety – Fine tolerance house chain grade T, (Types T, DAT and DT)
Federal Specifications	
FF-C-450	Clamps, wire rope
RR-C-271	Alloy hi-load standard shackles
ISO Standards	
ISO 7593	Chain slings assembled by methods other than welding

Related publications list

Note: every effort has been made to ensure that the documents, websites and webpages listed in this Appendix were correct at the time of publication. However, please note that documents and website addresses not under the control of the Ministry of Business, Innovation and Employment may change without notice.

Ministry of Business, Innovation and Employment publications

- *Approved Code of Practice for Cranes – Includes the Design, Manufacture, Supply, Safe Operation, Maintenance and Inspection of Cranes*
- *Approved Code of Practice for the Safe Handling, Transportation and Erection of Precast Concrete*
- *Best Practice Guidelines for Scaffolding in New Zealand* (owned by the Scaffolding and Rigging Association of New Zealand (SARNZ) and endorsed by the Ministry)
- *Guidelines for the Provision of Facilities and General Safety and Health in the Construction Industry*
- *Code of Practice for Safety and Health in Port Operations* (endorsed by the Maritime Safety Authority of New Zealand)
- *Best Practice Guidelines for Working at Height in New Zealand*

Health and safety publications can be accessed at www.mbie.govt.nz (click on 'Labour' in 'Our websites', then 'Health and Safety'. **Note:** some industry-produced publications listed on the website need to be purchased directly from the industry association.

Other publications

- Lifting Equipment Engineers New Zealand (LEENZ) Inc. *Code of Practice for the Safe Use of Lifting Equipment*. Available from www.leenz.org.
- *Maritime Rules Part 49, (Ships' Lifting Appliances)* available from the Maritime Safety Authority of New Zealand. Website: www.maritimenz.govt.nz/Rules
- *Radio Certification Licence Rules Engineering Rules and Information for Approved Radio Certifiers and Approved Radio Engineers*. Available from Radio Spectrum Management (part of the Ministry of Business, Innovation and Employment – Economic Development Group). Website: www.rsm.govt.nz/cms
- Crane Association of New Zealand (Inc). *Crane Association Crane Safety Manual*. Available from www.cranes.org.nz/about/publications/.

