

## FACT SHEET

# SAFE USE OF WOOD CHIPPERS

**This fact sheet provides guidance for those working in arboriculture. It outlines the protection needed for operators of hand-fed wood chippers.**

Wood chippers can be dangerous for operators and others working nearby. All operators should be trained and competent to operate a chipper, as there is always a risk of getting caught and pulled into the infeed rollers.

Operators should be protected from contact with the infeed rollers by a combination of reach distance guarding (created by the shape and dimensions of the infeed chute) and a correctly positioned protection device which, when activated, stops the infeed rollers.

### AS/NZS 4024.1:2014 - SAFETY OF MACHINERY

AS/NZS 4024 is the minimum standard for machine safety in New Zealand. It states that the height of the lower edge/end of the infeed chute shall be between 600 mm and 1000 mm from the ground, and the minimum horizontal distance from the infeed rollers to any part of the outer edges of the chute shall be 1500 mm.

Should an operator choose to apply another standard, it must be equivalent to or better than AS/NZS 4024.

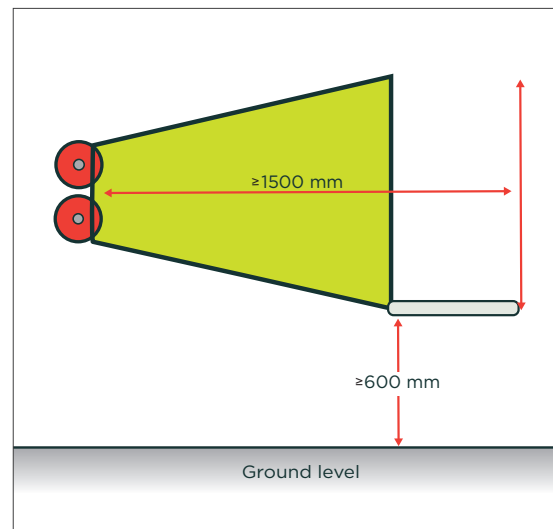
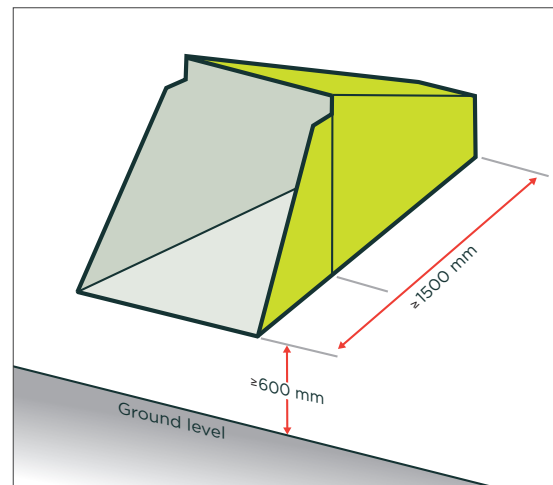

Figures 1 and 2: These illustrate AS/NZS 4024.1

## PROTECTION DEVICES - DESIGN, POSITION AND FUNCTION

The design and position of protection devices should allow the operator to readily activate them using parts of his/her body (eg hand, elbow, hip, torso etc).

This will be possible if the protection device:

- > can be pushed to the stop position without any interference by the edge of the chute
- > covers a minimum of 75% of each vertical projection (reverse feed roller bar) at the sides of the chute and 100% of the horizontal projection at the top (reverse feed roller bar) or bottom (bump bar) of the chute
- > ensures that, on all sides of the chute, the result of actuating the device is identical.

Ensure that the protection device operates by:

- > stopping the infeed action when pushed in the feeding direction
- > stopping or reversing the infeed action when pulled against the feeding direction.

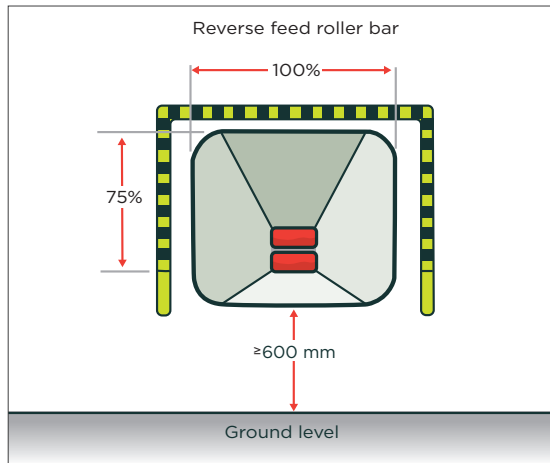

Make sure protection devices:

- > are robustly constructed and mounted so they remain operational in daily use (eg adequate points for lubrication and protection against dirt etc)

- > are designed to reduce the collection of debris in areas which would impede the full movement of the device
- > cannot be easily removed or disconnected
- > are suitably labelled to indicate the nature and function of the operator controls
- > ensure any manufacturer warning labels about the potential hazards of the wood chipper are visible and well maintained.

## MODIFICATIONS

Each manufacturer designs their chipper to a particular national or international standard in terms of safety features and use. Chippers redesigned and adapted from the manufacturer's choice of standard may be in breach of this chosen standard, and could compromise the safety of the machine.

Where a chipper is modified, it should be done in consultation with the manufacturer, and/or certified by an engineer as safe.

## TRAINING AND USAGE

Operators must be trained to use the machine safely and should always follow the manufacturer's instructions. Training needs to cover:

- > instruction on the machine's controls
- > the machine's safety features, why they are needed, and how to check them
- > how to position the machine so that the outermost lower edge of the infeed chute is the correct height above the ground
- > how to use the chipper safely
- > safe ways to avoid and remove blockages, eg keeping the chipping knives sharp and correct setting of the infeed roller and chipping component speed.

The training on safe use should include the following key points:

- > always wear close-fitting clothing and suitable personal protective equipment (PPE)

- > operate the chipper from a position where the protection device can be readily activated
- > when feeding the chipper, keep your face and body away from the infeed opening and stand to the side of the cutters and feed rollers to avoid particles thrown back
- > always use a long branch as a push-stick to feed short material
- > never jam, disable or remove any safety device on the machine
- > never reach into the infeed chute without stopping the infeed rollers
- > ensure all the machine components are at a complete standstill before carrying out maintenance, repairs or cleaning, or making any adjustment to the chipper.

**Note:** There may be other aspects of the machine on which operators need to be trained. The above is a general overview.

#### **DEVELOP A SAFE WORK PROCEDURE**

Develop, implement and use a standard operating procedure (SOP) for chipper use, based on manufacturer recommendations.

This should cover:

- > PPE requirements
- > hazards associated with the machine
- > safety features and use
- > operation - including starting, feeding and shutting down
- > process for clearing blockages
- > emergency procedures
- > maintenance
- > transport, including loading and unloading.

#### **OTHER DUTIES**

Designers, manufacturers, importers, sellers and suppliers have a range of duties to ensure that plant is not a cause or source of harm to those who use, store, construct, or carry out other activities such as cleaning or maintenance.

Persons conducting a business or undertaking (PCBUs) must systematically identify the existing and new hazards to workers and implement safeguards to eliminate or reduce the risk.

#### **FURTHER REFERENCES**

- > AS/NZS 4024.1:2014 Safety of Machinery
- > ANSI Z133-2012 for Arboricultural Operations - Safety Requirements
- > EN60204-1 Safety of machinery. Electrical equipment of machines. General requirements
- > EN982 Safety of machinery. Safety requirements for fluid power systems and their components. Hydraulics
- > EN13525: 2005 + A2 2009. Forestry machinery. Wood chippers. Safety
- > ISO 11448 Powered shredders and chippers - Definitions, safety requirements and test procedures
- > HSE UK publication 'Power-Fed mobile wood chippers-operator protection at infeed chutes' (the source of the diagrams in this fact sheet)
- > Worksafe New Zealand 'Best Practice Guidelines for Safe Use of Machinery - May 2014'
- > WorkSafe/MBIE Position Paper for the Safe Use of Machinery - November 2013

This publication provides general guidance, and has been developed in collaboration with the arboriculture industry. As it is not possible to address or anticipate every situation that could occur in every workplace this is simply a guide. However, it is the responsibility of duty holders to ensure that they are meeting their duties under health and safety legislation.

---

**PUBLISHED: MAY 2016. CURRENT UNTIL REVIEW IN 2018.**